



Solutions sur mesure pour votre usinage
Machining solutions especially for you

FRAISAGE



FRAISAGE

■ Fraises à Surfacer



0440.90 à 75° Page 06
0440.99 à 75° Page 06



0442.99 à 75° Page 07



1748.90 à 45° Page 07



1430.90 à 75° Page 08



1846.90 à 42° Page 08



130 FS à R6 Page 09



130 FSR à R6 Page 09

■ Fraises à Surfacer & Chanfreiner



0748.90 à 45° Page 10
0758.99 à 45° Page 10



0744.90 à 45° Page 11



0630.90 à 45° Page 11



0640.90 à 45° Page 11

■ Fraises à Chanfreiner



0740.00 à 45° Page 12
0740.07 à 45° Page 12
0740.30 à 45° Page 12



130 FC à 45° Page 13

■ Fraises Hérission



23_4.07 à plaq CC P 14



23_34.90 à plaq SC P 14



2234 à plaq SC P 14



23_0.07 à plaq AP P 15



2330 à plaq AP P 15



2240.90 à plaq AP+SP P 15

■ Fraises à Rainurer

Plaquette AP



1240.99 à 90° Page 16

Plaquette TP



0130.90 à 90° Page 17



0140.90 à 90° Page 17

■ Fraises T



1314.07 à 1344.07 Page 18
1314.30 à 1344.34 Page 18

■ Fraises à Tronçonner / Scier



0830.95 à 0840.95 Page 19



0930.95 à 0950.95 Page 20



1520.90 Page 21
1530.90 Page 21
1549.90 Page 21



1942.90 Page 22



2942.90 Page 22

■ Fraises à Détourer & Copier



130 DC à R5 Page 23



130 DCH à R5 Page 23

■ Fraises à Copier



130 CO à R10 Page 24

■ Fraises à Copier Mono-Plaquette



130 MP à R10 Page 25 à 28

■ Fraises à Lamer



130 FL Page 29

■ Fraises à Fileter



130 FI à Plaquette TC Page 30

Fraises Spéciales à la demande

(voir exemples en page 31)



Vous pouvez nous consulter pour tous vos outils spéciaux.

Nous répondons rapidement à vos demandes.

Nous vous offrons des prestations complètes en matière de conseils d'usinage, d'études techniques et avec mise en route pour les cas difficiles.



■ 0440.90 à 75° – 0440.99 à 75°

Fraise à surfer à plaquette SP

0440.90 à 75° Plaquette à fixation bridée

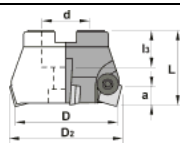

REFERENCE	Z	D	D2	L	d	l3	a
0440.90.040	3	40	46	40	16	18	9
0440.90.050	3	50	56	40	22	20	9
0440.90.063	4	63	69	50	27	22	9
0440.90.080	5	80	86	50	32	25	9
0440.90.100	6	100	106	50	40	29	9
0440.90.125	6	125	131	63	40	30	9
0440.90.160	7	160	166	63	40	30	9
0440.90.200	8	200	206	63	60	40	9

ACCESSORIES						
0440.90.040	1006	5004	2066	-	-	1058
0440.90.050	1006	5004	2066	3012	4012	912,10
0440.90.063	1006	5004	2066	3012	4012	912,12
0440.90.080	1006	5004	2066	3012	4012	912,17
0440.90.100	1006	5004	2066	3012	4012	912,20
0440.90.125	1006	5004	2066	3012	4012	-
0440.90.160	1006	5004	2066	3012	4012	912,52
0440.90.200	1006	5004	2066	3012	4012	912,56
PLAQUETTE	d		l		s	
SP.. 1203..	12,70		12,70		3,18	

Plaquette Positive carrée à 11°

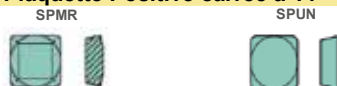

0440.99 à 75° Plaquette sur cartouche

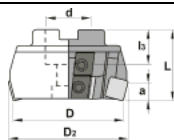

REFERENCE	Z	D	D2	L	d	l3	a
0440.99.080	5	80	86	50	27	22	9
0440.99.100	7	100	106	50	32	25	9
0440.99.125	8	125	131	63	40	30	9
0440.99.160	10	160	166	63	40	30	9
0440.99.200	12	200	206	63	60	40	9
0440.99.250	16	250	256	63	60	40	9
0440.99.315	20	315	321	63	60	40	9
0440.99.400	26	400	406	63	60	40	9
0440.99.500	34	500	506	63	60	40	9

ACCESSORIES									DIN 2079
0440.99.080	1077	5620	6437	6438	6914	1460	912,12	-	-
0440.99.100	1077	5620	6437	6438	6914	1460	912,20	-	-
0440.99.125	1077	5620	6437	6438	6914	1460	-	-	-
0440.99.160	1077	5620	6437	6438	6914	1460	912,52	40	-
0440.99.200	1077	5620	6437	6438	6914	1460	912,56	50	-
0440.99.250	1077	5620	6437	6438	6914	1460	912,56	50	-
0440.99.315	1077	5620	6437	6438	6914	1460	912,56	50/60	-
0440.99.400	1077	5620	6437	6438	6914	1460	912,56	50/60	-
0440.99.500	1077	5620	6437	6438	6914	1460	912,56	50/60	-
PLAQUETTE	d		l		s				
SP.. 1203..	12,70		12,70		3,18				

Plaquette Positive carrée à 11°

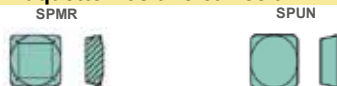

■ 0442.99 à 75° - 1748.90 à 45°

Fraise à surfacer à plaquette SK... et SE...

0442.99 à 75° Plaquette sur cartouche

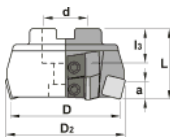

REFERENCE	Z	D	D2	L	d	l3	a
0442.99.080	5	80	86	50	27	22	9
0442.99.100	7	100	106	50	32	25	9
0442.99.125	8	125	131	63	40	30	9
0442.99.160	10	160	166	63	40	30	9
0442.99.200	12	200	206	63	60	40	9
0442.99.250	16	250	256	63	60	40	9
0442.99.315	20	315	321	63	60	40	9
0442.99.400	26	400	406	63	60	40	9
0442.99.500	34	500	506	63	60	40	9

ACCESSORIES									
0442.99.080	1077	5620	6432	6438	6912	912,12	-	-	0442.99.080
0442.99.100	1077	5620	6432	6438	6912	912,17	-	-	0442.99.100
0442.99.125	1077	5620	6432	6438	6912	-	-	-	0442.99.125
0442.99.160	1077	5620	6432	6438	6912	912,52	40	-	0442.99.160
0442.99.200	1077	5620	6432	6438	6912	912,56	50	-	0442.99.200
0442.99.250	1077	5620	6432	6438	6912	912,56	50	-	0442.99.250
0442.99.315	1077	5620	6432	6438	6912	912,56	50/60	-	0442.99.315
0442.99.400	1077	5620	6432	6438	6912	912,56	50/60	-	0442.99.400
0442.99.500	1077	5620	6432	6438	6912	912,56	50/60	-	0442.99.500

PLAQUETTE	d	l	s
SN.. 1204..	12,70	12,70	4,76

Plaquette Négative carrée

SNUN



1748.90 à 45° Plaquette à vis

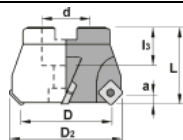

REFERENCE	Z	D	D2	L	d	l3	a
1748.90.050	4	50	62	40	22	20	6
1748.90.063	5	63	75	50	22	20	6
1748.90.080	6	80	92	50	27	22	6
1748.90.100	6	100	112	50	32	26	6
1748.90.125	7	125	132	63	40	29	6
1748.90.160	8	160	172	63	40	29	6
1748.90.200	10	200	212	63	60	40	6

ACCESSORIES				
1748.90.050	1550	5620	912,10	-
1748.90.063	1550	5620	912,10	-
1748.90.080	1550	5620	912,12	-
1748.90.100	1550	5620	912,17	-
1748.90.125	1550	5620	-	-
1748.90.160	1550	5620	912,52	40
1748.90.200	1550	5620	912,56	50

PLAQUETTE	d	l	s
SEH.. 1204..	12,70	12,70	4,76

Plaquette Positive carrée à 20°

SEHT

SEHW



■ 1846.90 à 42° – 1430.90 à 75°

Fraise à surfacer à plaquette OD ... et AP ...

1846.90 à 42° Plaquette à vis

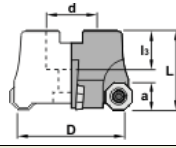

REFERENCE	Z	D	L	d	l3	a	REFERENCE
1846.90.063	4	63	50	27	25	8	1846.90.063
1846.90.080	5	80	50	32	26	8	1846.90.080
1846.90.100	6	100	50	40	29	8	1846.90.100
1846.90.125	8	125	63	40	29	8	1846.90.125
1846.90.160	10	160	63	40	29	8	1846.90.160
1846.90.200	12	200	63	60	40	8	1846.90.200

ACCESSORIES				
1846.90.063	1250	5620	912,12	-
1846.90.080	1250	5620	912,16	-
1846.90.100	1250	5620	912,20	-
1846.90.125	1250	5620	-	-
1846.90.160	1250	5620	912,52	40
1846.90.200	1250	5620	912,56	50

PLAQUETTE	d	l	s
ODM.. 0605..	16,00	6,00	5,55



Plaquette Positive octogonale à 15°

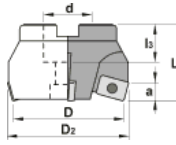

1430.90 à 75° Plaquette à vis



REFERENCE	Z	D	D2	L	d	l3	a
1430.90.050	3	50	54	40	16	22	7
1430.90.063	4	63	67	50	27	25	7
1430.90.080	5	80	84	50	32	25	7
1430.90.100	6	100	104	50	40	29	7

ACCESSORIES			
1430.90.050	1240	5615	1058
1430.90.063	1240	5615	912,12
1430.90.080	1240	5615	912,17
1430.90.100	1240	5615	912,20

PLAQUETTE	d	l	s
AP.. 1604..	9,52	17,00	4,76

Plaquette Positive rectangulaire à 11°



FS – Rayon 6 Plaquette à vis



REFERENCE	ØD	Ød	H	Z
130 FS 11	40	16	40	3
130 FS 12	50	22	40	3
330 FS 1204	50	22	40	4
130 FS 13	60	27	50	4
130 FS 14	80	27	50	5
130 FS 15	100	40	70	6

ACCESSORIES		
FS --	262 4008	263 824

PLAQUETTE	d	l	s
RP.. 1204..	12	12	4.76

Plaquette Positive Ronde à 11°

Code Plaq. Nuance Ref. commande	RPMT 12-04-MO-SN CR 15 260 0321	RPMT 12-04-MO-SN CR 35 260 0327	RPMT 12-04-MO-EN-85 CR 15 260 0323	RPMW 12-04-MO-SN CR 15 260 0325	RPMW 12-04-MO-SN S 28 260 0322	RPMW 12-04-MO-SN MR 15 260 0320	RPMX 12-04-MOT TTM 260 0302
---------------------------------------	---------------------------------------	---------------------------------------	--	---------------------------------------	--------------------------------------	---------------------------------------	-----------------------------------



Z = Nb de dents

FSR – Rayon 6 Plaquette à vis

Intérieur dégagé
pour travail en
plongée

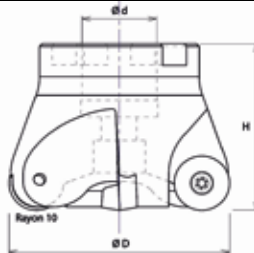
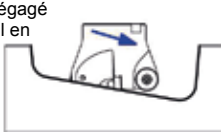

REFERENCE	ØD	Ød	H	Z
130 FSR 063	63	22	50	3
130 FSR 070	70	27	60	4
130 FSR 0804	80	27	60	4
130 FSR 0805	80	27	60	5
130 FSR 0835	83	27	60	5
130 FSR 100	100	32	65	5
130 FSR 120	120	32	60	5
130 FSR 160	160	40	65	7

ACCESSORIES		
FSR --	262 265	263 994

PLAQUETTE	d	l	s
RC.. 2004..	20	20	6.35

Plaquette Positive Ronde à 7°

Code Plaq. Nuance Ref. commande	RCMT 20-06-MO-SN-XR S 28 260 0350	RCMT 20-06-MO-SN-XR RX 16 260 0351	RCMT 20-06-MO-SN-XR S 21 260 0352
---------------------------------------	--------------------------------------	---------------------------------------	--------------------------------------



■ 0748.90 – 0758.99

Fraise à surfacer et chanfreiner à plaquette type S

0748.90 à 45°

Fraise à Surfacer / chanfreiner
Plaquette à fixation bridée

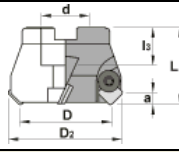

REFERENCE	Z	D	D2	L	d	l3	a
0748.90.050	4	50	63	40	22	20	6
0748.90.063	5	63	76	50	22	20	6
0748.90.080	6	80	93	50	27	22	6
0748.90.100	6	100	113	50	32	25	6
0748.90.125	7	125	138	63	40	30	6
0748.90.160	8	160	173	63	40	30	6
0748.90.200	10	200	213	63	60	30	6

ACCESSORIES							
0748.90.050	1006L	5004	2063	3010	4012	912,10	-
0748.90.063	1006L	5004	2063	3010	4012	912,10	-
0748.90.080	1006L	5004	2063	3010	4012	912,12	-
0748.90.100	1006L	5004	2063	3010	4012	912,17	-
0748.90.125	1006L	5004	2063	3010	4012	-	-
0748.90.160	1006L	5004	2063	3010	4012	912,52	40
0748.90.200	1006L	5004	2063	3010	4012	912,56	50

PLAQUETTE	d	l	s
SEK.. 1203..	12,70	12,70	3,18

Plaquette Positive carrée à 7°



0758.99 à 45°

Fraise à Surfacer / chanfreiner
Plaquette sur cartouche

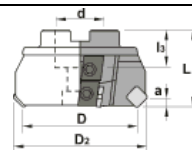

REFERENCE	Z	D	D2	L	d	l3	a
0758.99.080	6	80	98	50	27	22	9
0758.99.100	8	100	118	50	32	25	9
0758.99.125	8	125	143	63	40	30	9
0758.99.160	10	160	178	63	40	30	9
0758.99.200	12	200	218	63	60	40	9
0758.99.250	16	250	268	63	60	40	9

ACCESSORIES							
0758.99.080	1077	5620	6490	6491	6920	1460	912,12
0758.99.100	1077	5620	6490	6491	6920	1460	912,17
0758.99.125	1077	5620	6490	6491	6920	1460	-
0758.99.160	1077	5620	6490	6491	6920	1460	912,52
0758.99.200	1077	5620	6490	6491	6920	1460	912,56
0758.99.250	1077	5620	6490	6491	6920	1460	912,56

PLAQUETTE	d	l	s
SEK.. 1504..	15,88	15,88	4,76

Plaquette Positive carrée à 20°



■ 0744.90 – 0630.90 – 0640.90

Fraise à surfer – chanfreiner

0744.90 à 45°

Fraise à Surfer - chanfreiner
Plaquette à vis

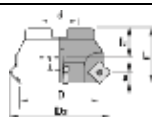

REFERENCE	Z	D	D2	L	d	l3	a
0744.90.040	4	40	57	40	16	18	7
0744.90.050	4	50	67	40	22	20	7
0744.90.063	5	63	80	50	27	22	7
0744.90.080	6	80	97	50	32	25	7
0744.90.100	7	100	117	50	40	29	7
0744.90.125	8	125	142	63	40	30	7
0744.90.160	9	160	177	63	40	30	7
0744.90.200	11	200	217	63	60	40	7

ACCESSORIES				
0744.90.040	1250	5620	1058	-
0744.90.050	1250	5620	912,10	-
0744.90.063	1250	5620	912,12	-
0744.90.080	1250	5620	912,16	-
0744.90.100	1250	5620	912,20	-
0744.90.125	1250	5620	-	-
0744.90.160	1250	5620	912,52	40
0744.90.200	1250	5620	912,56	50

PLAQUETTE	d	l	s
SC.. 1204..	12,70	12,70	4,76

Plaquette Positive carrée à 7°

SCMW

SCMT



0630.90 à 45°

Fraise à Surfer - chanfreiner
Plaquette à fixation bridée



REFERENCE	Z	D	D2	L	d	l3	a
0630.90.032	3	32	54	50	22	20	8
0630.90.040	3	40	62	50	27	22	8
0630.90.050	4	50	72	50	27	22	8
0630.90.063	4	63	85	50	32	25	8
0630.90.080	5	80	102	50	40	29	8

ACCESSORIES						
0630.90.032	1006	2064	3016	4016	5004	912,10
0630.90.040	1006	2064	3016	4016	5004	912,12
0630.90.050	1006	2064	3016	4016	5004	912,12
0630.90.063	1006	2064	3016	4016	5004	912,16
0630.90.080	1006	2064	3016	4016	5004	912,20

PLAQUETTE	d	l	s
TPUN 1603..	9,52	16,50	3,18

Plaquette Positive triangulaire à 11°

TPGN

TPMR

TPUN



0640.90 à 45°

Fraise à Surfer - chanfreiner
Plaquette à fixation bridée



REFERENCE	Z	D	D2	L	d	l3	a
0640.90.032	3	32	62	50	22	20	11
0640.90.040	3	40	70	50	27	22	11
0640.90.050	4	50	80	50	27	22	11
0640.90.063	4	63	93	50	32	25	11
0640.90.080	5	80	110	50	40	29	11

ACCESSORIES						
0640.90.032	1008	2088	3022	4022	5005	912,10
0640.90.040	1008	2088	3022	4022	5005	912,12
0640.90.050	1008	2088	3022	4022	5005	912,12
0640.90.063	1008	2088	3022	4022	5005	912,16
0640.90.080	1008	2088	3022	4022	5005	912,20

PLAQUETTE	d	l	s
TPUN 2204..	12,70	22,00	4,76

Plaquette Positive triangulaire à 11°

TPGN

TPMR

TPUN



■ 0740.00 – 0740.07 – 0740.30

Fraise à Chanfreiner à Plaquette Type S

0740.00 à 45° Plaquette à vis

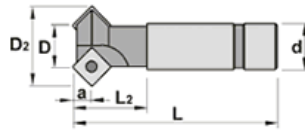

REFERENCE	z	D	D2	L	L2	d	a
0740.00.005	1	6,5	22	110	35	20	7
0740.00.020	2	20,0	37	125	35	25	7

0740.07 à 45° Plaquette à vis

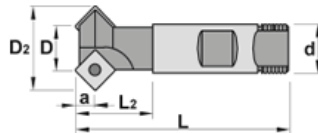

REFERENCE	z	D	D2	L	L2	d	a
0740.07.005	1	6,5	22	110	35	25	7
0740.07.020	2	20,0	37	110	35	25	7

0740.30 à 45° Plaquette à vis

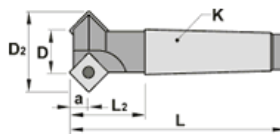

REFERENCE	z	D	D2	L	L2	a	K
0740.30.005	1	6,5	22	125	39	7	MK3
0740.30.020	2	20,0	37	125	39	7	MK3

ACCESSORIES



0740.00..	1550	5520
0740.07..	1550	5520
0740.30..	1550	5520

PLAQUETTE

	d	l	s
SPM.. 1204..	12,70	12,70	4,76

Plaquette Positive carrée à 11°

SPMT

SPMW



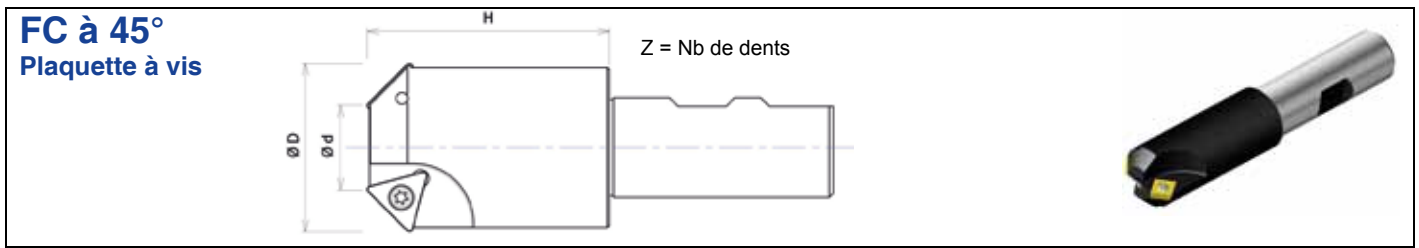





REFERENCE	ØD	Ød	H	Z	Attachement	Plaquette
130 FC 01	42	20	60	2	QC 25 Weldon	TCMT 16 T3 08
130 FC 02	26	13	50	2	QC 20 Weldon	TCMT 11 02 04
130 FC 03	20	12	50	2	QC 16 Weldon	CCMT 06 02 04
130 FC 04	16	3	45	1	QC 12 Weldon	TCMT 11 02 04

ACCESSORIES		
130 FC 01		262 388
130 FC 02 - 03 - 04		263 824
		263 866

PLAQUETTE	d	l	s
TC.. 1102..	6.35	11	2.38
TC.. 16T3..	9.52	16	3.97
CC.. 0602..	6.35	6.45	2.38

Plaquette Positive à 7°

Code Plaq. Nuance Ref. commande	TCMT 16-T3-08 EN S 21 260 0402	TCMT 16-T3-08 RX 16 260 0404	TCMT 11-02-04 XM 1 S 21 260 0401	CCMT 06-02-04 TTR 260 0201	CCMT 06-02-04 XM 1 S 21 260 0206
					

■ 23_4.07 – 2234.90 – 2234

Fraise Hérisson à Plaquette

23_4.07 Plaquette à vis

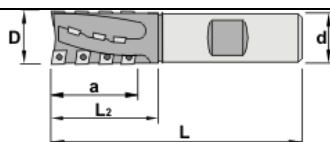

REFERENCE	Z	D	L	L2	d	a	Insert
2314.07.025.30	2+2	25	125	60	25	30	CC.. 0602.. (12)
2314.07.025.43	2+2	25	125	60	25	43	CC.. 0602.. (16)
2324.07.032.30	2+2	32	130	60	32	30	CC.. 0803.. (12)
2324.07.032.43	2+2	32	130	60	32	43	CC.. 0803.. (16)
2334.07.040.30	2+2	40	130	60	32	30	CC.. 09T3.. (12)
2334.07.040.43	2+2	40	130	60	32	43	CC.. 09T3.. (16)

ACCESSORIES			
2314..		1225	5607
2324..		1230	5608
2334..		1240	5615

PLAQUETTE	d	l	s
CC.. 0602..	6,35	6,45	2,38
CC.. 0803..	7,94	8,05	3,18
CC.. 09T3..	9,52	9,65	3,97

Plaquette Rhombique à 80° - Positive



2234.90 Plaquette à vis



REFERENCE	Z	D	L	d	a	SC.. 1204..	SC.. 09T3..
2234.90.063.65	2+2	63	80	27	65	2	18
2234.90.080.75	2+3	80	90	32	75	2	22
2234.90.100.85	3+3	100	100	40	85	3	36
2234.90.125.95	4+4	125	110	40	95	4	52

ACCESSORIES					
2234.90.063.65		1250	5620	1240	912,12
2234.90.080.75		1250	5620	1240	912,16
2234.90.100.85		1250	5620	1240	912,20
2234.90.125.95		1250	5620	1240	-

2234 Plaquette à vis

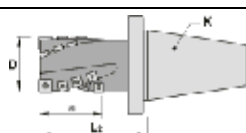

ISO DIN 2080	ISO 7388 DIN 69871 A	ISO BT System	Z	D	L2	K	a	SC.. 1204..	SC.. 09T3..
2234.44.040.60	2234.47.040.60	2234.49.040.60	1+2	40	105	40	60	1	13
2234.44.050.65	2234.47.050.65	2234.49.050.65	1+2	50	105	40	65	1	14
2234.45.040.70	2234.48.040.70	2234.50.040.70	1+2	40	123	50	70	1	14
2234.45.050.75	2234.48.050.75	2234.50.050.75	1+2	50	128	50	75	1	16
2234.45.063.80	2234.48.063.80	2234.50.063.80	2+2	63	133	50	80	2	22
2234.45.080.85	2234.48.080.85	2234.50.080.85	2+3	80	138	50	85	2	28
2234.45.100.95	2234.48.100.95	2234.50.100.95	3+3	100	148	50	95	3	39

ACCESSORIES				
2234..		1250	5620	5615

PLAQUETTE	d	l	s
SC.. 09T3..	9,52	9,52	3,97
SC.. 1204..	12,70	12,70	4,76

Plaquette Positive carrée à 7°

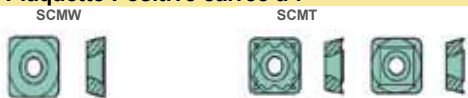

■ 23_0.07 – 2330 – 2240.90

Fraise Hérisson à Plaquette

23_0.07 Plaquette à vis

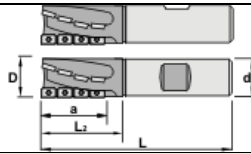



REFERENCE	Z	D	L	L2	K	a	Insert
2320.07.025.37	2	25	110	50	25	37	AP.. 1003..
2330.07.032.45	2	32	125	55	32	45	AP.. 1604..
2330.07.040.50	3	40	125	65	32	50	AP.. 1604..

ACCESSORIES		
2320.07.025.37		1425
2330.07..		5507
		1440
		5515

PLAQUETTE	d	l	s
AP.. 1003..	6,35	9,52	3,18
AP.. 1604..	9,52	17,00	4,76

Plaquette Positive rectangulaire à 11°

APFT  APKT  APMT 

2330 Plaquette à vis

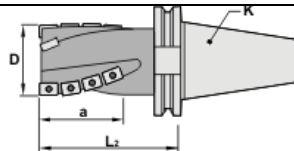

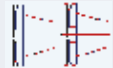

REFERENCE	
	

ISO 7388 DIN 69871 A	ISO BT System	Z	D	L2	K	a	Insert
2330.47.050.65	2330.49.050.65	3	50	105	40	65	AP.. 1604..
2330.48.050.65	2330.50.050.65	3	50	105	50	65	AP.. 1604..
2330.48.063.65	2330.50.063.65	3	63	130	50	65	AP.. 1604..
2330.48.080.85	2330.50.080.85	3	80	140	50	80	AP.. 1604..

ACCESSORIES		
2330.47..		1240
2330.48..		5615
		1240
		5615

PLAQUETTE	d	l	s
AP.. 1604..	9,52	17,00	4,76







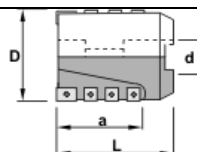



Plaquette Positive rectangulaire à 11°

APFT  APKT  APMT 

2240.90 Plaquette à vis





REFERENCE	Z	D	L	d	a	AP.. 2004..	SPM.. 1204..
2240.90.050.48	1+2	50	70	22	48	1	11
2240.90.063.58	2+2	63	70	27	58	2	10
2240.90.080.68	3+2	80	80	32	68	2	16
2240.90.100.78	3+3	100	90	40	78	3	21
2240.90.125.88	4+4	125	100	40	88	4	32

ACCESSORIES			
2240.90.050.48		1550	
2240.90.063.58		1550	
2240.90.080.68		1550	
2240.90.100.78		1550	
2240.90.125.88		1550	

PLAQUETTE	d	l	s
AP.. 2004..	12,70	20,00	4,76
SPM. 1204..	12,70	12,70	4,76

Plaquette Positive rectangulaire à 11° **Plaquette Positive carrée à 11°**

APFT  APKT  APMT  SPMT  SPMW 

■ 1240-99 – RC





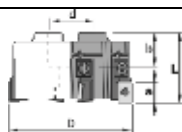

Fraise à Rainurer

1240-99 à 90° Plaquette à vis sur cartouche



REFERENCE	Z	D	L	L2	d	a
1240.99.160	10	160	63	40	30	14
1240.99.200	12	200	63	60	40	14
1240.99.250	16	250	63	60	40	14
1240.99.315	20	315	63	60	40	14
1240.99.400	22	400	63	60	40	14
1240.99.500	28	500	63	60	40	14

ACCESSOIRES

						
1240.99.160	1550	5620	6240	1788	1460	40
1240.99.200 .. 250	1550	5620	6240	1788	1460	50
1240.99.315 .. 500	1550	5620	6240	1788	1460	50/60

Plaquette

	l	s	d
AP.. 2004...	20,00	4,76	12,70

Plaquette Rhombique Positive à 11°

APFT



APKT



APMT



0130.90 – 0140.90

Fraise à Rainurer

0130.90 à 90° Plaquette Bridée

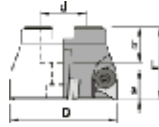

REFERENCE	Z	D	L	d	a	SC.. 1204..
0130.90.040	3	40	40	16	13	13
0130.90.050	4	50	40	22	13	13
0130.90.050.Z=3	3	50	40	22	13	13
0130.90.063	4	63	50	27	13	13
0130.90.080	5	80	50	32	13	13
0130.90.100	6	100	50	40	13	13
0130.90.125	6	125	63	40	13	13
0130.90.160	7	160	63	40	13	13
0130.90.200	8	200	63	60	13	13

ACCESSOIRES							
0130.90.040	1006	5004	2064	-	-	1058	-
0130.90.050	1016	5004	2064	-	-	912,10	-
0130.90.050.Z=3	1006	5004	2064	-	-	912,10	-
0130.90.063	1006	5004	2064	3016	4016	912,12	-
0130.90.080	1006	5004	2064	3016	4016	912,16	-
0130.90.100	1006	5004	2064	3016	4016	912,20	-
0130.90.125	1006	5004	2064	3016	4016	-	-
0130.90.160	1006	5004	2064	3016	4016	912,52	40
0130.90.200	1006	5004	2064	3016	4016	912,56	50

Plaquette	l	s	d
TP.. 1603..	16,50	3,18	9,52

Plaquette Triangulaire positive à 11°



0140.90 à 90° Plaquette Bridée

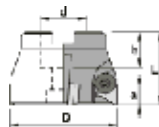

REFERENCE	Z	D	L	d	a	SC.. 1204..
0140.90.063	3	63	50	27	18	18
0140.90.080	4	80	50	32	18	18
0140.90.100	5	100	50	40	18	18
0140.90.125	6	125	63	40	18	18
0140.90.160	7	160	63	40	18	18
0140.90.200	8	200	63	60	18	18

ACCESSOIRES							
0140.90.063	1008	5005	2088	3022	4016	912,12	-
0140.90.080	1008	5005	2088	3022	4016	912,16	-
0140.90.100	1008	5005	2088	3022	4016	912,20	-
0140.90.125	1008	5005	2088	3022	4016	-	-
0140.90.160	1008	5005	2088	3022	4016	912,52	40
0140.90.200	1008	5005	2088	3022	4016	912,56	50

Plaquette	l	s	d
TP.. 2204..	22,00	4,76	12,70

Plaquette Triangulaire positive à 11°





■ 1314.07 – 1314.30

Fraise à Rainurer

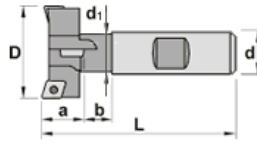

1314.07 à 1344.07 Plaquette à vis

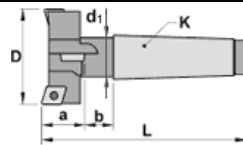

REFERENCE	z	D	L	d	d1	a	b
1314.07.025.11	2+2	25	85	25	12	11	17
1324.07.032.14	2+2	32	95	25	15	14	22
1334.07.040.18	2+2	40	105	25	19	18	27
1344.07.050.22	2+2	50	120	32	25	22	34
ACCESSORIES							
1314.07.025.11		1225				5507	
1324.07.032.14		1230				5508	
1334.07.040.18		1240				5515	
1344.07.050.22		1250				5520	

1314.30 à 1344.34 Plaquette à vis



REFERENCE	z	D	L	K	d1	a	b
1314.30.025.11	2+2	25	125	MK3	12	11	17
1324.30.032.14	2+2	32	125	MK3	15	14	22
1334.30.040.18	2+2	40	134	MK3	19	18	27
1344.34.050.22	2+2	50	165	MK4	25	22	34
ACCESSORIES							
1314.30.025.11		1225				5507	
1324.30.032.14		1230				5508	
1334.30.040.18		1240				5515	
1344.34.050.22		1250				5520	

PLAQUETTE	D	l	s
CC.. 0602..	6,35	6,45	2,38
CC.. 0803..	7,94	8,05	3,18
CC. 09T3..	9,52	9,65	3,97
CCM.. 1204..	12,70	12,90	4,76

Plaquette rhombique à 80° - POSITIVE



■ 0830.95 – 0840.95

Fraise à Tronçonner / Scier à plaq Type T

0830.95 / 0840.95

Plaquette sur cassette



REFERENCE	z	D	b	d	A	B	D1	E	a
0830.95.100.16	6	100	16	27	7	29,8	41	18	28
0830.95.125.16	8	125	16	32	8	34,8	48	18	39
0830.95.125.18	8	125	18	32	8	34,8	48	20	39
0830.95.125.20	8	125	20	32	8	34,8	48	22	39
0830.95.125.22	8	125	22	32	8	34,8	48	24	39
0830.95.160.16	10	160	16	40	10	43,5	58	18	49
0830.95.160.18	10	160	18	40	10	43,5	58	20	49
0830.95.160.20	10	160	20	40	10	43,5	58	22	49
0830.95.160.22	10	160	22	40	10	43,5	58	24	49
0830.95.200.16	12	200	16	50	12	53,8	72	18	60
0830.95.200.18	12	200	18	50	12	53,8	72	20	60
0830.95.200.20	12	200	20	50	12	53,8	72	22	60
0830.95.250.20	16	250	20	50	12	53,8	72	22	86
0830.95.315.24	20	315	24	50	12	53,8	84	26	114
0840.95.315.32	16	315	32	50	12	53,8	84	34	114
0840.95.400.32	20	400	32	50	12	53,8	84	34	150

ACCESSOIRES

0830.95..16-24	1088	1094	6010	6110	6562	6563	5004	5003
0830.95..32	1088	1096	6011	6111	6564	6565	5004	5005

Plaquette

	l	s	d
TP.. 1603..	16,50	3,18	9,52

Plaquette Triangulaire positive à 11°

TPGN	TPMR	TPUN

■ 0930.95 – 0950.95

Fraise à Tronçonner et Scier

0930.95 / 0950.95 Plaquette sur cassette

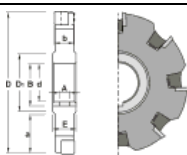

REFERENCE	z	D	b	d	A	B	D1	E	a
0930.95.050.10	6	50	10	16	4	18,0	28	12	10
0930.95.063.10	6	63	10	22	6	24,5	35	12	12
0930.95.080.10	8	80	10	22	6	24,5	35	12	20
0930.95.100.10	10	100	10	27	7	29,8	41	12	28
0930.95.100.12	10	100	12	27	7	29,8	41	14	28
0930.95.100.14	10	100	14	27	7	29,8	41	16	28
0930.95.125.10	12	125	10	32	8	34,8	48	12	39
0930.95.125.12	12	125	12	32	8	34,8	48	14	39
0930.95.125.14	12	125	14	32	8	34,8	48	16	39
0930.95.160.10	14	160	10	40	10	43,5	58	12	49
0930.95.160.12	14	160	12	40	10	43,5	58	14	49
0930.95.160.14	14	160	14	40	10	43,5	58	16	49
0940.95.080.16	6	80	16	22	6	24,5	35	18	20
0940.95.100.16	8	100	16	27	7	29,8	41	18	28
0940.95.125.16	10	125	16	32	8	34,8	48	18	39
0940.95.125.18	10	125	18	32	8	34,8	48	20	39
0940.95.125.20	10	125	20	32	8	34,8	48	22	39
0940.95.160.16	12	160	16	40	10	43,5	58	18	49
0940.95.160.18	12	160	18	40	10	43,5	58	20	49
0940.95.160.20	12	160	20	40	10	43,5	58	22	49
0940.95.200.16	16	200	20	50	12	53,8	72	18	60
0940.95.200.18	16	200	18	50	12	53,8	72	20	60
0940.95.200.20	16	200	18	50	12	53,8	72	22	60
0940.95.250.20	20	250	20	50	12	53,8	72	22	86
0940.95.250.24	20	250	24	50	12	53,8	72	26	86
0940.95.315.24	24	315	24	50	12	53,8	72	26	114
0950.95.315.30	20	315	30	50	12	53,8	72	32	114
0950.95.400.30	24	400	30	50	12	53,8	72	32	150

ACCESSOIRES

0930.95.050.10	1156	1194		6036	6037			
0930.95.063.10	1156	1194		6036	6037			
0930.95.080.10	1266	1194						
0930.95.100.10	1266	1194						
0930.95.100.12	1266	1294						
0930.95.100.14	1266	1294						
0930.95.125.10	1066	1194	1504	6013	6103	5615	5509	5002
0930.95.125.12	1066	1294						
0930.95.125.14	1066	1294						
0930.95.160.10	1066	1194						
0930.95.160.12	1066	1294						
0930.95.160.14	1066	1294						
0940.95.080.16	1388	1295						
0940.95.100.16		1295						
0940.95.125.16		1295						
0940.95.125.18		1195						
0940.95.125.20		1195						
0940.95.160.16		1295						
0940.95.160.18		1195						
0940.95.160.20		1195						
0940.95.200.16	1088	1295	1505	6010	6110		5004	5025
0940.95.200.18		1195						
0940.95.200.20		1195						
0940.95.250.20		1195						
0940.95.250.24		1195						
0940.95.315.24		1195						
0950.95.315.30		1196	1506	6011	6111			5005

Plaquette	l	s	d
SP.. 0903..	9,52	3,18	9,52
SP.. 1203..	12,70	3,18	12,70
SP.. 1504..	15,88	4,76	15,88

Plaquette Carrée positive à 11°

SPMR



SPUN



■ 1520.90 – 1530.90 – 1549.90

Fraise à Tronçonner et Scier

1520.90 Plaquette vissée

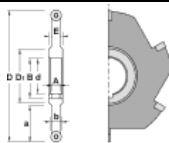

REFERENCE	z	D	b	d	A	B	D1	E	a
1520.90.050	5	50	8	16	4	18,0	28	10	10
1520.90.063	6	63	8	22	6	24,5	35	10	12
1520.90.080	7	80	8	22	6	24,5	35	10	20
1520.90.100	8	100	8	27	7	29,8	41	10	28
1520.90.125	9	125	8	32	8	34,8	48	10	39
1520.90.160	10	160	8	40	10	43,5	58	10	49
1520.90.200	12	200	8	50	12	53,8	72	10	60

ACCESSOIRES



1520.90..	1230	5608
Plaquette	s	d
RPMW 0802M0	2,38	8,00

Plaquette Ronde positive à 11°

RPMW



1530.90 Plaquette vissée

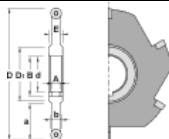

REFERENCE	z	D	b	d	A	B	D1	E	a
1530.90.050	5	50	10	16	4	18,0	28	12	10
1530.90.063	5	63	10	22	6	24,5	35	12	12
1530.90.080	6	80	10	22	6	24,5	35	12	20
1530.90.100	7	100	10	27	7	29,8	41	12	28
1530.90.125	8	125	10	32	8	34,8	48	12	39
1530.90.160	9	160	10	40	10	43,5	58	12	49
1530.90.200	10	200	10	50	12	53,8	72	12	60
1530.90.250	12	250	10	50	12	53,8	72	12	86

ACCESSOIRES



1530.90..	1240	5615
Plaquette	s	d
RPMW 1003M0	3,18	10,00

Plaquette Ronde positive à 11°

RPMW



1549.90 Plaquette vissée

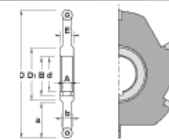

REFERENCE	z	D	b	d	A	B	D1	E	a
1549.90.080	6	80	12	22	6	24,5	35	14	20
1549.90.100	7	100	12	27	7	29,8	41	14	28
1549.90.125	8	125	12	32	8	34,8	48	14	39
1549.90.160	9	160	12	40	10	43,5	58	14	49
1549.90.200	10	200	12	50	12	53,8	72	14	60
1549.90.250	12	250	12	50	12	53,8	72	14	86

ACCESSOIRES



1549.90..	1240	5615
Plaquette	s	d
RPMW 1204M0	4,76	12,00

Plaquette Ronde positive à 11°

RPMW



■ 1942.90 – 2942.90

Fraise à Tronçonner et Scier

1942.90 Plaquette vissée

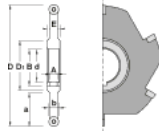

REFERENCE	z	D	b	d	A	B	D1	E	a
1942.90.100.04	12	100	4	27	7	29,8	41	12	25
1942.90.125.04	14	125	4	32	8	34,8	48	12	40
1942.90.100.05	12	100	5	27	7	29,8	41	12	25
1942.90.125.05	14	125	5	32	8	34,8	48	12	40
1942.90.160.05	18	160	5	40	10	43,5	58	12	44
1942.90.100.06	10	100	6	27	7	29,8	41	12	25
1942.90.125.06	12	125	6	32	8	34,8	48	12	40
1942.90.160.06	16	160	6	40	10	43,5	58	12	44
1942.90.200.06	18	200	6	50	12	53,8	72	12	54
1942.90.250.06	24	250	6	50	12	53,8	72	12	79
1942.90.100.08	10	100	8	27	7	29,8	41	12	25
1942.90.125.08	12	125	8	32	8	34,8	48	12	40
1942.90.160.08	16	160	8	40	10	43,5	58	12	44
1942.90.200.08	18	200	8	50	12	53,8	72	12	54
1942.90.250.08	24	250	8	50	12	53,8	72	12	79
1942.90.100.10	10	100	10	27	7	29,8	41	12	25
1942.90.125.10	12	125	10	32	8	34,8	48	12	40
1942.90.160.10	16	160	10	40	10	43,5	58	12	44
1942.90.200.10	18	200	10	50	12	53,8	72	12	54
1942.90.250.10	24	250	10	50	12	53,8	72	12	79
1942.90.100.12	10	100	12	27	7	29,8	41	16	25
1942.90.125.12	12	125	12	32	8	34,8	48	16	40
1942.90.160.12	16	160	12	40	10	43,5	58	16	44
1942.90.200.12	18	200	12	50	12	53,8	72	16	54
1942.90.250.12	24	250	12	50	12	53,8	72	16	79

ACCESSOIRES



1942.90...04	1735	5607
1942.90...05	1835	5607
1942.90...06	1745	5615
1942.90...08	1846	5615
1942.90...10	1845	5615
1942.90...12	1847	5615

Plaquette	L	S	d
SNHX 1102XX	11,00	2,38	11,00
SNHX 1103XX	11,00	2,70	11,00
SNHX 1203XX	12,70	3,18	12,70
SNHX 12045XX	12,70	4,50	12,70
SNHX 1205XX	12,70	5,40	12,70
SNHX 1207XX	12,70	7,00	12,70

Plaquette Négative carrée tangentielle

SNHX



2942.90 Plaquette à gorge

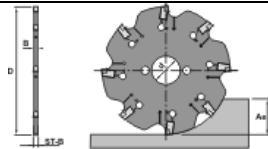

REFERENCE	z	ST-B	B	D	d	Ae	Rev max	Insert
2942.90.0801.2	4	1,6	1,2	80	16	22	1000	FRC.. 1,6
2942.90.0801.8	4	2,2	1,8	80	16	22	1000	FRC.. 2,2
2942.90.0802.4	4	3,0	2,4	80	16	22	1000	FRC.. 3,0
2942.90.0803.0	4	4,0	3,0	80	16	22	1000	FRC.. 4,0
2942.90.0804.4	4	5,0+6,0	4,4	80	16	22	1000	FRC.. 5,0-6,0
2942.90.1001.2	8	1,6	1,2	100	22	28	800	FRC.. 1,6
2942.90.1001.8	8	2,2	1,8	100	22	28	800	FRC.. 2,2
2942.90.1002.4	8	3,0	2,4	100	22	28	800	FRC.. 3,0
2942.90.1003.0	8	4,0	3,0	100	22	28	800	FRC.. 4,0
2942.90.1004.4	8	5,0+6,0	4,4	100	22	28	800	FRC.. 5,0-6,0
2942.90.1251.2	10	1,6	1,2	125	22	40	650	FRC.. 1,6
2942.90.1252.8	10	2,2	1,8	125	22	40	650	FRC.. 2,2
2942.90.1252.4	10	3,0	2,4	125	22	40	650	FRC.. 3,0
2942.90.1253.0	10	4,0	3,0	125	22	40	650	FRC.. 4,0
2942.90.1254.4	10	5,0+6,0	4,4	125	22	40	650	FRC.. 5,0-6,0
2942.90.1602.4	15	3,0	2,4	160	32	49	500	FRC.. 3,0
2942.90.1603.0	15	4,0	3,0	160	32	49	500	FRC.. 4,0
2942.90.1604.4	15	5,0+6,0	4,4	160	32	49	500	FRC.. 5,0-6,0
2942.90.2002.4	20	3,0	2,4	200	40	63	400	FRC.. 3,0
2942.902003.0	20	4,0	3,0	200	40	63	400	FRC.. 4,0
2942.902004.4	20	5,0+6,0	4,4	200	40	63	400	FRC.. 5,0-6,0
2942.90.2502.4	24	3,0	2,4	250	40	88	300	FRC.. 3,0
2942.90.2503.0	24	4,0	3,0	250	40	88	300	FRC.. 4,0
2942.90.2504.4	24	5,0+6,0	4,4	250	40	88	300	FRC.. 5,0-6,0

ACCESSOIRES



2942.90..	5733
-----------	------

Plaquette	L	S
FRC 1,6	1,6	0,15
FRC 2,2	2,2	0,20
FRC 3,0	3,0	0,20
FRC 4,0	4,0	0,20
FRC 5,0	5,0	0,30
FRC 6,0	6,0	0,30
FRCR 3,0	3,0	1,50
FRCR 4,0	4,0	2,00
FRCR 5,0	5,0	2,50
FRCR 6,0	6,0	3,00

Plaquette Négative carrée tangentielle

FRC



FRCR



DC – Rayon 5
Plaquette à vis

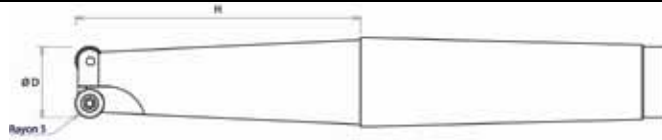

REFERENCE	ØD	Attachement	H	Z
130 DC 01	25	CM 4	100	2
130 DC 02		CM 3	80	
130 DC 03		QC W 20	50	
130 DC 04	30	CM 4	100	3
130 DC 05		CM 3	80	
130 DC 06		QC W 25	50	

Z= Nb de dents

ACCESSORIES

-- DC --		262 388		263 824
----------	---	---------	---	---------

PLAQUETTE

RPM. 1003MO	d	l	s
	10	10	3,18

Plaquette Positive Ronde à 11°

Code Plaq. Nuance Ref. commande	RPMW 10-03-MO-EN S 28 260 0326	RPMW 10-03-MO-EN CR 35 260 0328
------------------------------------	-----------------------------------	------------------------------------



DCH – Rayon 5
Plaquette à vis

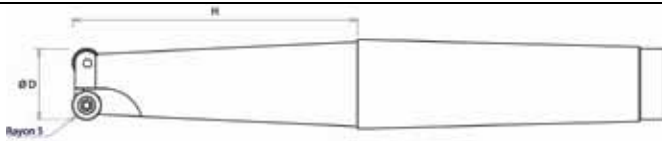

REFERENCE	ØD	Attachement	H	Z
130 DCH 01	25	CM 4	100	2
130 DCH 02		CM 3	80	
130 DCH 03		QC W 20	50	
130 DCH 04	30	CM 4	100	3
130 DCH 05		CM 3	80	
130 DCH 06		QC W 25	50	

ACCESSORIES

-- DCH --		262 388		263 824
-----------	---	---------	---	---------

PLAQUETTE

RD.. 1003...	d	l	s
	10	10	3,18

Plaquette Positive Ronde à 15°

Code Plaq. Nuance Ref. commande	RDHW 10-03-MOS CR 15 260 0343	RDHW 10-03-MOS S 28 260 0346	RDMW 10-03-MO TTM 260 0311
------------------------------------	----------------------------------	---------------------------------	-------------------------------



CO – Rayon 10
Plaquette à vis

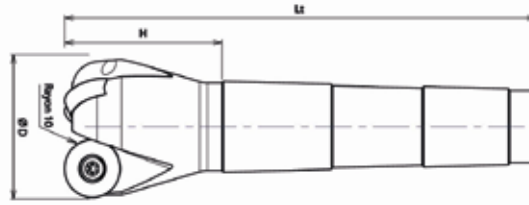

REFERENCE	ØD	Attachement	Lt	H	Z
130 CO 11	25	CM 4	180	70	1
130 CO 10	50		164	55.5	3
130 CO 13			209	100	

ACCESSORIES				
-- CO --	 262 265		 263 994	
PLAQUETTE	d	L	s	
RCMT 2006MO	20	20	6 735	

Plaquette Positive Ronde à 7°

Code Pla. Nuance RCMT 20-06-MO SN-XR S 28 RCMT 20-06-MO SN-XR RX 16 RCMT 20-06-MO SN-XR S 21
 Ref. commande 260 0350 260 0351 260 0352



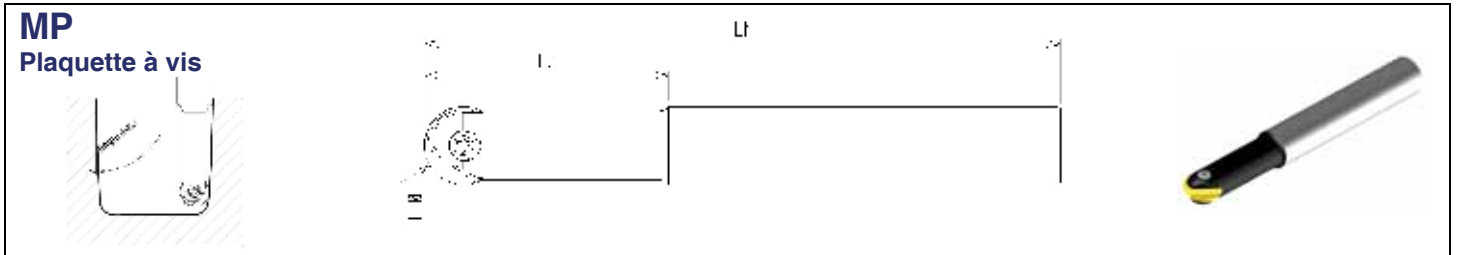

REFERENCE	ØD	Attachement	Lu	Lt	Angle maxi	Plaquette
130 MP 01	10	QC Ø12	35 à 85	115	2°	PRD 10
130 MP 02	12	QC Ø12	40 à 90	120	-	PRD 12
130 MP 03	16	QC Ø16	50 à 100	130	-	PRD 16
130 MP 04	20	QC Ø20	60 à 120	160	-	PRD 20

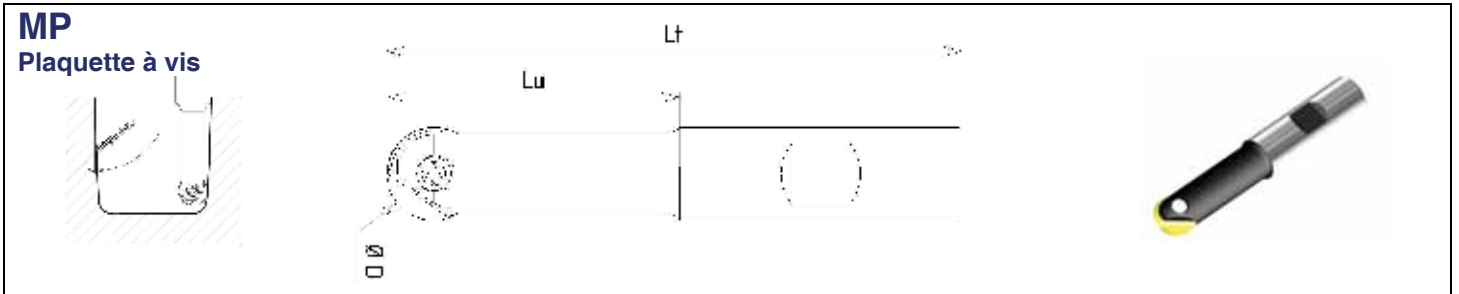

REFERENCE	ØD	Attachement	Lu	Lt	Angle maxi	Plaquette
130 MP 11	10	QCW Ø12	35	80	-	PRD 10
130 MP 12	12	QCW Ø12	40	85	-	PRD 12
130 MP 13	16	QCW Ø16	50	98	-	PRD 16
130 MP 14	20	QCW Ø20	60	110	-	PRD 20

ACCESSORIES		
130 MP 01 ou 130 MP 11		VRD 10
130 MP 02 ou 130 MP 12		VRD 12
130 MP 03 ou 130 MP 13		VRD 16
130 MP 04 ou 130 MP 14		VRD 20
		263 866
		263 866
		263 824
		263 994

PLAQUETTE	d	l	s
PRD 10	10	10	2,6
PRD 12	12	12	3
PRD 16	16	16	4
PRD 20	20	20	5

Plaquette Positive Ronde à 15°

Code Plaq. Nuance Ref. commande	PRD 10 REP 4 MG 10 01833983320	PRD 10 REP 4 MG 10X 01833983327X	PRD 12 REP 4 MG 10 01833982320	PRD 12 REP 4 MG 10X 01833982327X	PRD 16 REP 4 MG 10 01833981320	PRD 16 REP 4 MG 10X 01833981327X	PRD 20 REP 4 MG 10 01832979320	PRD 20 REP 4 MG 10X 0183

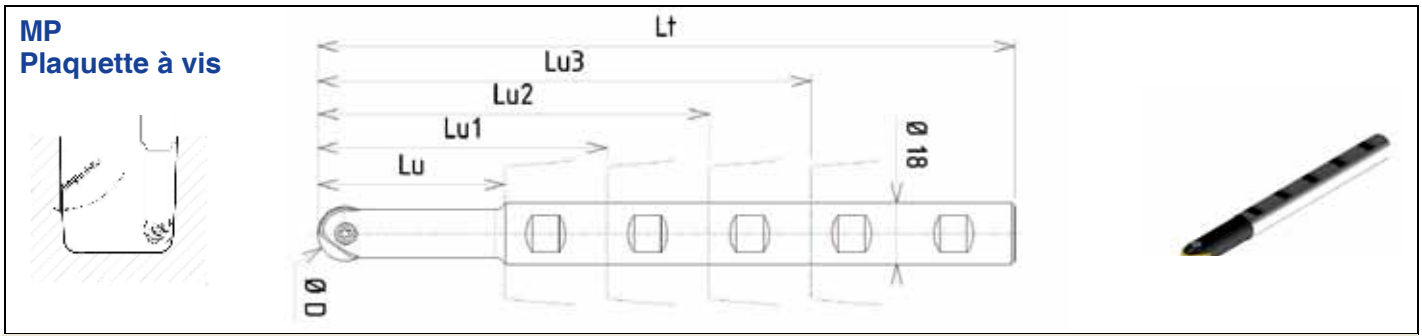

REFERENCE	ØD	Attachement	Lu	Lu1	Lu2	Lu3	Lt	Angle maxi	Plaquette
130 MP 21	10	QC Rallongé Ø18 (4plats)	40	70	100	-	154	6.5°	PRD 10
130 MP 22	12		45	75	105	-	159	4.5°	PRD 12
130 MP 23	16	QC Rallongé Ø18 (5plats)	55	85	115	145	205	1.5°	PRD 16
130 MP 24	20		60	90	110	150	210	-	PRD 20

ACCESSORIES			SA 40 DIN 2080	CAT 40 DIN 69871	SA 50 DIN 2080	CAT 50 DIN 69871
130 MP 21	VRD 10	263 866	142041806	142141806	142051806	142151808
130 MP 22	VRD 12	263 866	142041806	142141806	142051806	142151808
130 MP 23	VRD 16	263 824	-	-	142051806	142151808
130 MP 24	VRD 20	263 994	-	-	142051806	142151808



PLAQUETTE	d	l	s
PRD 10	10	10	2,6
PRD 12	12	12	3
PRD 16	16	16	4
PRD 20	20	20	5

Plaquette Positive Ronde à 15°

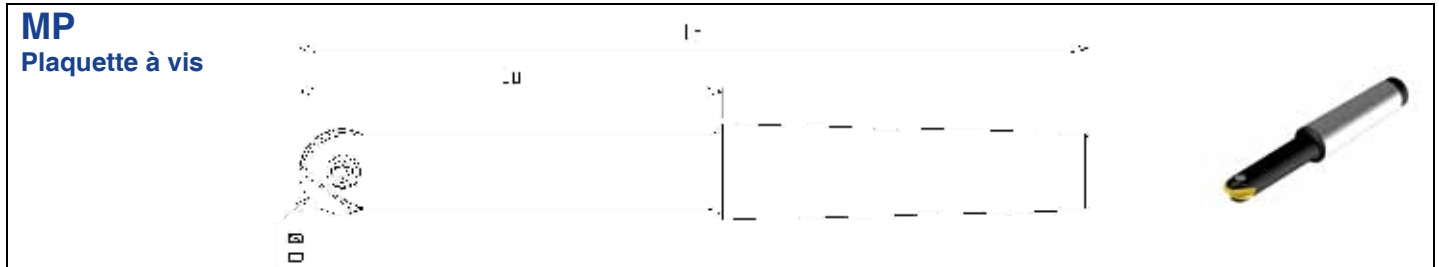
Code Plaq. Nuance Ref. commande	PRD 10 REP 4 MG 10 01833983320	PRD 10 REP 4 MG 10X 01833983327X	PRD 12 REP 4 MG 10 01833982320	PRD 12 REP 4 MG 10X 01833982327X	PRD 16 REP 4 MG 10 01833981320	PRD 16 REP 4 MG 10X 01833981327X	PRD 20 REP 4 MG 10 01832979320	PRD 20 REP 4 MG 10X 0183



REFERENCE	ØD	Attachement	Lu	Lt	Plaquette
130 MP 3103	10	CM 2 taraudé	30	99	PRD 10
130 MP 3106			60	129	
130 MP 3203	12		30	99	PRD 12
130 MP 3206			60	129	
130 MP 3304	16		40	109	PRD 16
130 MP 3308			80	149	
130 MP 3312		120	189		
130 MP 3404	20	CM 3 taraudé	40	126	PRD 20
130 MP 3408			80	166	
130 MP 3412			120	206	

ACCESSORIES		
130 MP 31..	VRD 10	263 866
130 MP 32..	VRD 12	263 866
130 MP 33..	VRD 16	263 824
130 MP 34..	VRD 20	263 994

PLAQUETTE	d	l	s
PRD 10	10	10	2,6
PRD 12	12	12	3
PRD 16	16	16	4
PRD 20	20	20	5

Plaquette Positive Ronde à 15°

Code Plaq. Nuance Ref. commande	PRD 10 REP 4 MG 10 01833983320	PRD 10 REP 4 MG 10X 01833983327X	PRD 12 REP 4 MG 10 01833982320	PRD 12 REP 4 MG 10X 01833982327X	PRD 16 REP 4 MG 10 01833981320	PRD 16 REP 4 MG 10X 01833981327X	PRD 20 REP 4 MG 10 01832979320	PRD 20 REP 4 MG 10X 0183
								

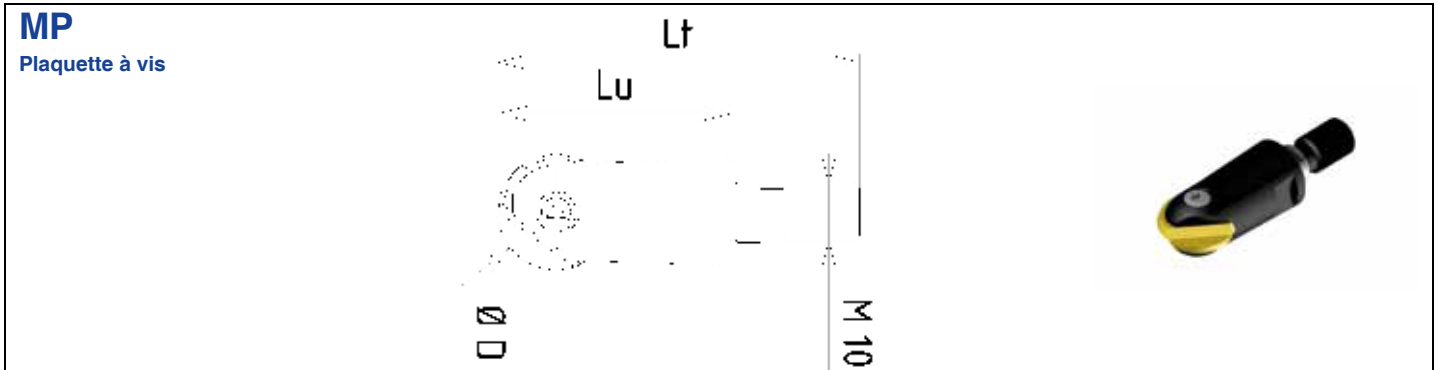

REFERENCE	ØD	Attachement	Lu	Lt	Plaquette
130 MP 43	16	A visser M10	35	57	PRD 16
130 MP 44	20		40	62	PRD 20

ACCESSORIES		
130 MP 23	VRD 16	263 824
130 MP 24	VRD 20	263 994

PLAQUETTE	d	l	s
PRD 16	16	16	4
PRD 20	20	20	5

Plaquette Positive Ronde à 15°

Code Plaq. Nuance Ref. commande	PRD 16 REP 4 MG 10 01833981320	PRD 16 REP 4 MG 10X 01833981327X	PRD 20 REP 4 MG 10 01832979320	PRD 20 REP 4 MG 10X 0183

Attachement pour fraise à copier à visser

REFERENCE	Lu	Lt	L1	Ø d1	Ø d2	Attachement
14145M1015	70	150	-	19	-	QC Ø 20 lisse
14145M1020	80	200	-	19	-	QC Ø 20 lisse
14133M1005	50	136	-	19	-	CM 3
14133M1008	80	166	40	19	24	CM 3
14114M1008	80	167.5	40	19	25	CAT 40 din 69871
14104M1008	70	175	30	19	24	SA 40 din 2080

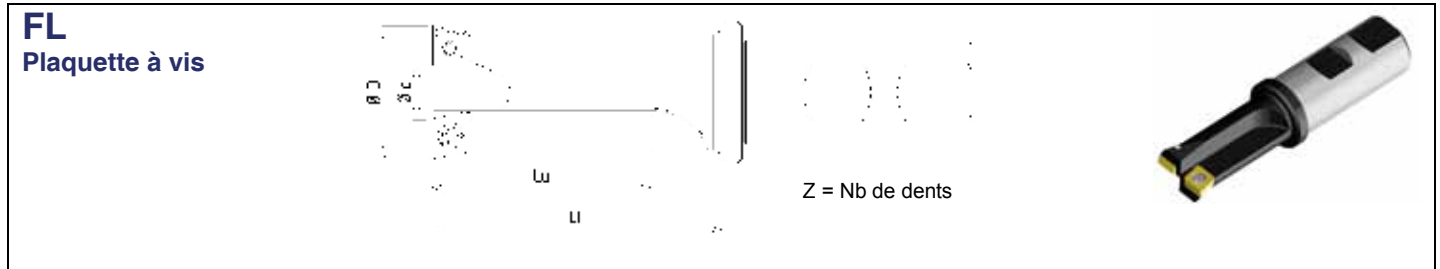

REFERENCE	Tête de vis CHC	Tête éjecteur	ØD	Ød mini	Lu	Lt	QC Weldon	Z	Plaquette
130 FL 01	M 5	5 / 6	10	0	25	35	12	1	CPGT 04T104 -3
130 FL 02	M 6	5 / 6	11.5	1	25	40			
130 FL 10	-	6 / 8	13	1	32	44			
130 FL 03	M 8		14.5	4	30	45			
130 FL 12	-	8 / 10	15	3	32	44	16	2	CCMT 060204
130 FL 04	M 10	10-11 / 12	17.5	6	40	55			
130 FL 05	M 12	12.5 / 14	20	12	40	55			
130 FL 11	-	12 / 16	21.5	10	52	65	20	2	CCMT 090304
130 FL 06	M 14	14-16 / 18	23	11.5	50	65			
130 FL 07	M 16	-	26	14.5	50	65			
130 FL 13	-	18 / 20	27	16	52	65	25	2	CCMT 090304
130 FL 08	M 18	-	29	11	62	75			
130 FL 09	M 20	-	32	14	62	75			

ACCESSORIES		
130 FL 01 - 02	262 060	263 059
130 FL 10 - 03 - 12 - 04 - 05 - 11 - 06 - 07 - 13	262 687	263 866
130 FL 08 - 09	262 388	263 824

PLAQUETTE	l	s	d
CCMT 060204	6,45	2,38	6,35
CCMT 090304	9,65	3,18	9,52

Plaquette Positive Rhombique à 7°

Code Plaq.	CCMT 060204	CCMT 060204 - XM1	CCMT 090304
Nuance	TTR	S 21	TTR
Ref. commande	260 0201	260 0206	260 0203



PLAQUETTE	l	s	d
CPGT 04T104	4.82	1.98	4.76

Plaquette Positive Rhombique à 11°

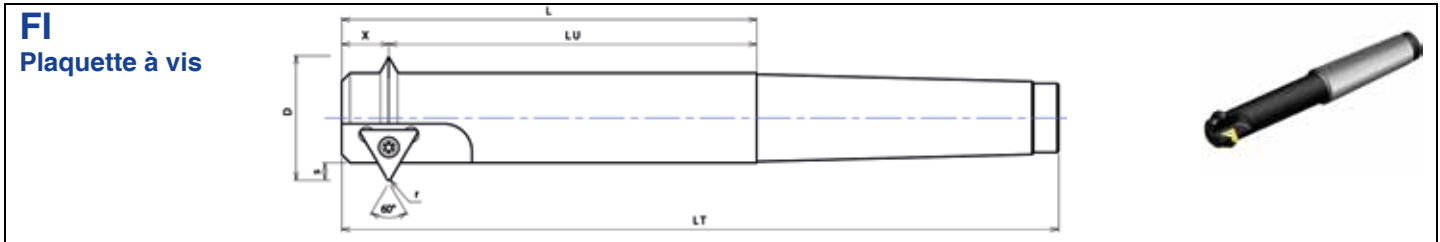
Code Plaq.	CPGT 04T104 - 3
Nuance	TTR
Ref. commande	260 0701



REFERENCE	Ø de passage	Pas	Ø Fileté mini	R	S mini	L	x	LT	Attachement	Z	Plaquette
130 FI 01	Ø 20	1.5	Ø 30	0.2	3.1	80	8.5	166	CM3	1	TCMT 110202
		2									
		2.5									
		3									
		3.5									
130 FI 02	Ø 35	3	Ø 52	0.4	4.4	125	13	234	CM4	1	TCMT 16T304
		3.5									
		4									
		4.5									
		5									
130 FI 03	Ø 45	5.5	Ø 68	0.8	6.1	150	17	259	CM4	1	TCMT 220408
		6									
		6.5									
		7									
		7.5									
8											

ACCESSORIES		
130 FI 01	262 126	263 060
130 FI 02	262 388	263 824
130 FI 03	262 072	263 994

PLAQUETTE	l	s	d
TCMT 110202	11,00	2,38	6,35
TCMT 16T304	16,50	3,97	9,52
TCMT220408	22,00	4,76	12,70

Plaquette Positive Triangulaire à 7°

Code Plaq. Nuance Ref. commande	TCMT 110202 TTR 260 0405	TCMT 16T304 TTR 260 0406	TCMT 220408 ENXR S 21 260 0403
			



Fraise à Chanfreiner Ø 580



Fraise à surfacer ravonnée



Jeu de Fraises Eclisse pour Rail de Chemin de Fer

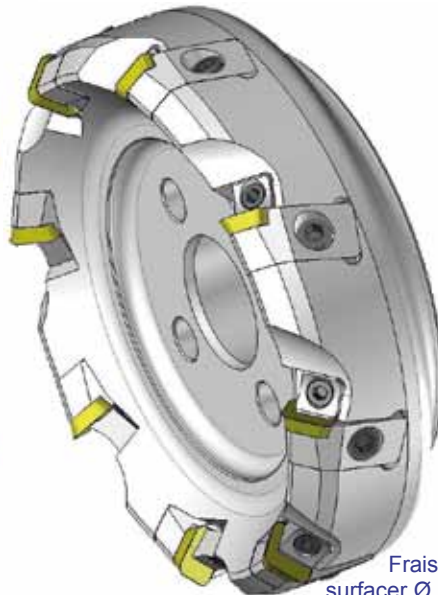

Fraise à surfacer Ø 160 en phase de conception



Fraise pour Graphite



Fraise en cours de fabrication



Fraise Carbure brasé Ø 160



Fraise Boule Ø 104



Fraise à surfacer Ø 500 pour usinage du Graphite

evatec tools®

Solutions sur mesure pour votre usinage
Machining solutions especially for you

CARBURE



PCBN / PCD



AÉRONAUTIQUE



TOURNAGE



USINAGE DE TROUS

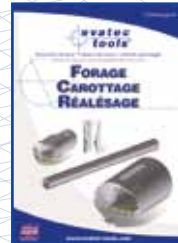

ATTACHEMENTS

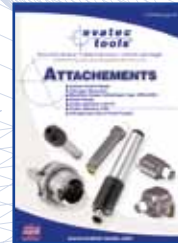

FRAISAGE

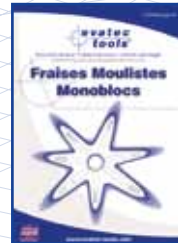

MÉTIERS / SPÉCIFIQUES



Téléchargez nos catalogues sur www.evatec-tools.com

Download our CATALOGS on www.evatec-tools.com

evatools® evamet® carbex® gmo®
coriatec® create outillage®

12, rue des Terres Rouges - Z.I. Metzange - 57100 Thionville

Tél. : 03 82 88 61 61 - E-mail : evatec@evatec-tools.fr

www.evatec-tools.com

