



Solutions sur mesure pour votre usinage
Machining solutions especially for you

FRAISES À FILETER

PAR INTERPOLATION

```
ONE PASS INCREMENTAL PROGRAM
S #DIV/0! M03 M08 G94
G91 X0 Y0 Z0
G01 Z- #DIV/0! F 25
G41 X 0,0000 Y- 0,0000 F #DIV/0!
G03 X 0,0000 Y 0,0000 I #DIV/0! J 0 J 0,0000 F #DIV/0!
G03 X- 0,0000 Y 0,0000 I #DIV/0! J 0 J- 0,0000 F #DIV/0!
G03 X- 0,0000 Y- 0,0000 I #DIV/0! J 0 J- 0,0000 F #DIV/0!
G03 X 0,0000 Y 0,0000 I #DIV/0! J 0 J 0,0000 F #DIV/0!
G03 X- 0,0000 Y 0,0000 I #DIV/0! J 0 J- 0,0000 F #DIV/0!
G01G40 X- 0,0000 Y- 0,0000 F 25
G00 Z #DIV/0!
TWO PASS INCREMENTAL PROGRAM
S #DIV/0! M03 M08 S 14
G91 X0 Y0 Z0
G01 Z- #DIV/0! F 25
G41 X #DIV/0! Y- #DIV/0! F #DIV/0!
G42 X #DIV/0! Y #DIV/0! F #DIV/0!
G03 X 0 Y 0 I 0 J 0 I #DIV/0! J #DIV/0! F #DIV/0!
G03 X- #DIV/0! Y #DIV/0! F #DIV/0!
G01G40 X- #DIV/0!
G01 Z- 0,0000 F 0,0000
G03 X- 0,0000 Y 0,0000 I 0,0000 J 0,0000 F #DIV/0!
G03 X 0,0000 Y 0,0000 I 0,0000 J 0,0000 F #DIV/0!
G03 X- 0,0000 Y- 0,0000 I 0,0000 J 0,0000 F #DIV/0!
G03 X 0,0000 Y- 0,0000 I 0,0000 J 0,0000 F #DIV/0!
G01G40 X- 0,0000 Y- 0,0000 F 25
G00 Z #DIV/0!
```

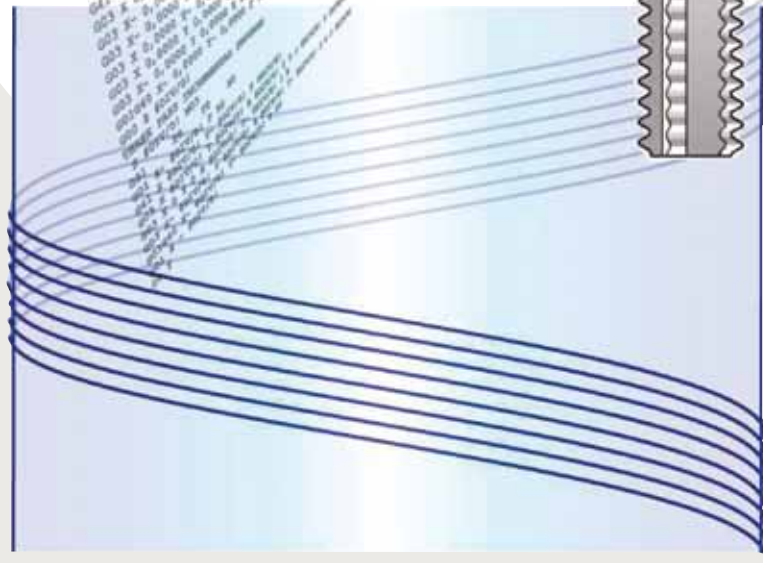

Sommaire

■ Fraises à Fileter Carbone Monobloc

- Fraise à fileter ISO 60° intérieur **Page 04**
- Fraise à fileter ISO Pas Fin 60° intérieur **Page 04**
- Fraise à fileter ISO Pas Fin 60° extérieur **Page 04**

- Fraise à fileter UN 60° intérieur **Page 05**
- Fraise à fileter UN Pas Fin 60° intérieur **Page 05**
- Fraise à fileter UN Pas Fin 60° extérieur **Page 05**

- Fraise à fileter BSW 55° intérieur/extérieur **Page 06**
- Fraise à fileter BSP 55° intérieur/extérieur **Page 06**
- Fraise à fileter BSPT 55° intérieur/extérieur **Page 06**
- Fraise à fileter NPT 55° intérieur/extérieur **Page 06**
- Fraise à fileter NPTF 60° intérieur/extérieur **Page 06**
- Fraise à fileter PG 80° intérieur/extérieur **Page 06**

- Fraise à fileter T2 ISO 60° interieur **Page 07**
- Fraise à fileter T2 ISO Pas Fin 60° interieur **Page 07**
- Fraise à fileter T2 UN 60° interieur **Page 07**
- Fraise à fileter T3 ISO 60° interieur **Page 07**
- Fraise à fileter T3 ISO Pas Fin 60° interieur **Page 07**
- Fraise à fileter T3 UN 60° interieur **Page 07**

- Fraise à fileter Ø 35 à Alésage ISO & UN 60° interieur **Page 08**
- Fraise à fileter Ø 45 à Alésage ISO & UN 60° interieur **Page 08**
- Fraise à fileter Ø 55 à Alésage ISO & UN 60° interieur **Page 08**

■ Fraises à fileter à plaquettes carbure indexable

- Plaquettes Carbure ISO 60° exterieur **Page 09**
- Plaquettes Carbure ISO 60° interieur **Page 09**
- Plaquettes Carbure UN 60° exterieur **Page 09**
- Plaquettes Carbure UN 60° interieur **Page 09**

- Plaquettes Carbure BSP 55° interieur/extérieur **Page 10**
- Plaquettes Carbure NPSM 60° interieur/extérieur **Page 10**
- Plaquettes Carbure NPSF 60° interieur/extérieur **Page 10**
- Plaquettes Carbure BSPT 55° interieur/extérieur **Page 10**
- Plaquettes Carbure NPT 60° interieur/extérieur **Page 10**
- Plaquettes Carbure NPTF 6° interieur/extérieur **Page 10**

- Fraise à Plaquettes Queue Cylindrique **Page 11**
- Fraise à Plaquettes à alésage **Page 11**
- Accessoires pour Fraise à Plaquettes **Page 11**

Fraise ISO 60° / ISO pas fin (*Standard Metric*) 

Fraise UN 60° / UN pas fin (*Unified National*) 

FraiseBSW 55° (*British Standard Witworth*)

FraiseBSP 55° (*British Standard Pipe*) 

FraiseBSPT 55° (*British Standard Pipe Taper*)

Fraise NPT 55° (*National Pipe*)

Fraise NPTF 60° (*National Pipe Taper*) 

Fraise PG 80°

Fraise T2 ISO & UN *Standard & Pas fin* 

Fraise T3 ISO & UN *Standard & Pas fin* 

Fraise Ø 35 45 & 55 ISO & UN 

Plaquette carbure ISO & UN 

Plaquette BSP 55° (*British Standard Pipe*)

Plaquette NPSM 60° (*National Pipe Straight Mechanical*) 

Plaquette NPSF 60° (*National Pipe Straight Dryseal*)

Plaquette BSPT 55° (*British Pipe Taper*)

Plaquette NPT 60° (*National Pipe*) 

Plaquette NPTF 60° (*National Pipe Taper*)

Fraise à Plaquette QC 

Fraise à Plaquette à alésage 



■ Fraise à Fileter

Carbure monobloc ISO 60°

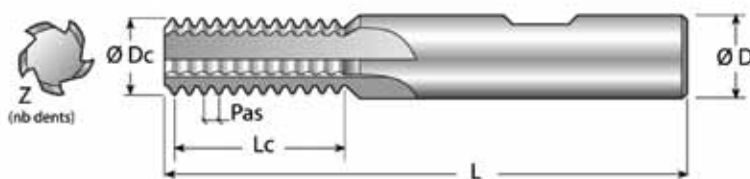

ISO 60°									
NORME	Référence Article		Z	L	Nb Filets / Lg coupe	Dc	D	Tarif	
M 1.6	x	0.35	TMSC 03010-N-0.35 ISO	3	38	7 - 2.45	1.00	3.00	
M 2	x	0.40	TMSC 03013-N-0.40 ISO	3	38	8 - 3.20	1.30	3.00	
M 2.5	x	0.45	TMSC 03015-N-0.45 ISO	3	38	8 - 3.60	1.50	3.00	
M 3	x	0.50	TMSC 03021-N-0.50 ISO	3	38	9 - 4.50	2.10	3.00	
M 4	x	0.70	TMSC 03026-N-0.70 ISO	3	38	9 - 6.30	2.60	3.00	
M 4.5	x	0.75	TMSC 04030-N-0.75 ISO	3	42	9 - 6.75	3.00	4.00	Nous
M 5	x	0.80	TMSC 04036-N-0.80 ISO	3	42	10 - 8.00	3.60	4.00	
M 6	x	1.00	TMSC 06040-N-1.00 ISO	3	57	9 - 9.00	4.00	6.00	Consulter
M 8	x	1.25	TMSC 06050-N-1.25 ISO	3	57	10 - 12.50	5.00	6.00	
M 10	x	1.50	TMSC 06059-N-1.50 ISO	5	57	10 - 15.00	5.90	6.00	
M 12	x	1.75	TMSC 08079-N-1.75 ISO	5	63	11 - 19.25	7.90	8.00	
M 16	x	2.00	TMSC 10099-N-2.00 ISO	5	72	12 - 24.00	9.90	10.00	
M 20	x	2.50	TMSC 12119-N-2.50 ISO	5	83	12 - 30.00	11.90	12.00	
M 24	x	3.00	TMSC 16159-N-3.00 ISO	6	92	12 - 36.00	15.90	16.00	
M 30*	x	3.50	TMSC 16159-N-3.50 ISO	6	92	11 - 38.50	15.90	16.00	
M 36*	x	4.00	TMSC 16159-N-4.00 ISO	6	92	10 - 40.00	15.90	16.00	
M 48*	x	5.00	TMSC 20199-N-5.00 ISO	6	104	8 - 40.00	19.90	20.00	
M 64*	x	6.00	TMSC 20199-N-6.00 ISO	6	104	6 - 36.00	19.90	20.00	

ISO 60° intérieur Pas Fin									
NORME	Référence Article		Z	L	Nb Filets / Lg coupe	Dc	D	Tarif	
M 10	x	0.50	TMSC 08079-N-0.50 ISO	5	63	30 - 15.0	7.90	8.0	
M 10	x	0.75	TMSC 06059-N-0.75 ISO	5	57	20 - 15.0	5.90	6.0	
M 12	x	1.00	TMSC 08079-N-1.00 ISO	5	63	20 - 20.0	7.90	8.0	
M 16	x	1.50	TMSC 10099-N-1.50 ISO	5	72	16 - 24.0	9.90	10.0	Nous
M 18	x	1.50	TMSC 12119-N-1.50 ISO	5	83	20 - 30.0	11.90	12.0	
M 20	x	2.00	TMSC 12119-N-2.00 ISO	5	83	15 - 30.0	11.90	12.0	Consulter
M 24	x	3.00	TMSC 16159-N-3.00 ISO	6	92	12 - 36.0	15.90	16.0	
M 36*	x	4.00	TMSC 16159-N-4.00 ISO	6	92	10 - 40.0	15.90	16.0	
M 64*	x	6.00	TMSC 20199-N-6.00 ISO	6	104	6 - 36.0	19.90	20.00	

ISO 60° extérieur Pas Fin									
NORME	Référence Article		Z	L	Nb Filets / Lg coupe	Dc	D	Tarif	
M 3	x	0.50	TMSC 06059-E-0.50 ISO	5	57	30 - 15.0	5.90	6.0	
M 3	x	0.50	TMSC 08079-E-0.50 ISO	5	63	30 - 15.0	7.90	8.0	
M 4.5	x	0.75	TMSC 08079-E-0.75 ISO	5	63	26 - 19.5	7.90	8.0	
M 6	x	1.00	TMSC 10099-E-1.00 ISO	5	72	24 - 24.0	9.90	10.0	Nous
M 10	x	1.50	TMSC 12119-E-1.50 ISO	5	72	20 - 30.0	11.90	12.0	
M 14	x	2.00	TMSC 12119-E-2.00 ISO	5	83	15 - 30.0	11.90	12.0	Consulter
M 24	x	3.00	TMSC 16159-E-3.00 ISO	6	83	12 - 36.0	15.90	16.0	
M 36*	x	4.00	TMSC 16159-E-4.00 ISO	6	92	10 - 40.0	15.90	16.0	
M 64*	x	6.00	TMSC 20199-E-6.00 ISO	6	104	6 - 36.00	19.90	20.00	

■ Fraise à Fileter

Carbure Monobloc UN 60°

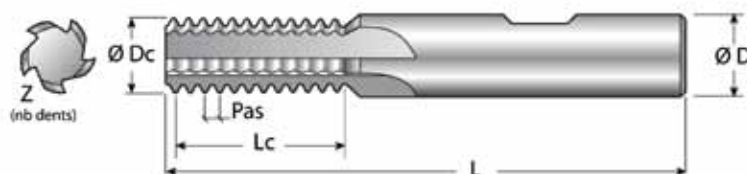

UN 60°									
NORME		Référence Article	Z	L	Nb Filets / Lg coupe	Dc	D	Tarif	
N° 2	x	0.397	TMSC 03015-N-64" UN	3	38	8 - 3.175	1.50	3.00	
N° 2	x	0.454	TMSC 03015-N-56" UN	3	38	7 - 3.175	1.50	3.00	
N° 3	x	0.529	TMSC 03015-N-48" UN	3	38	7 - 3.704	1.50	3.00	
N° 5	x	0.577	TMSC 03021-N-44" UN	3	38	8 - 4.618	2.10	3.00	
N° 4	x	0.635	TMSC 03021-N-40" UN	3	38	7 - 4.445	2.10	3.00	
N° 8	x	0.705	TMSC 04030-N-36" UN	3	42	9 - 6.350	3.00	4.00	
N° 8	x	0.794	TMSC 04030-N-32" UN	3	42	8 - 6.350	3.00	4.00	
N° 12	x	0.907	TMSC 04036-N-28" UN	3	57	9 - 8.165	3.60	4.00	
N° 12	x	1.058	TMSC 06040-N-24" UN	3	57	8 - 8.467	4.00	6.00	
1 / 4 "	x	1.270	TMSC 06040-N-20" UN	3	57	8 - 10.160	4.00	6.00	Nous
5 / 16 "	x	1.411	TMSC 06050-N-18" UN	3	57	9 - 12.700	5.00	6.00	
3 / 8 "	x	1.587	TMSC 06059-N-16" UN	5	57	9 - 14.287	5.90	6.00	Consulter
7 / 16 "	x	1.814	TMSC 08079-N-14" UN	5	63	9 - 16.328	7.90	8.00	
1 / 2 "	x	1.954	TMSC 08079-N-13" UN	5	63	10 - 19.538	7.90	8.00	
9 / 16 "	x	2.116	TMSC 10099-N-12" UN	5	72	11 - 23.283	9.90	10.00	
5 / 8 "	x	2.309	TMSC 10099-N-11" UN	5	72	10 - 23.091	9.90	10.00	
3 / 4 "	x	2.500	TMSC 12199-N-10" UN	5	83	11 - 27.490	11.90	12.00	
7 / 8 "	x	2.778	TMSC 16159-N- 9" UN	6	92	12 - 33.337	15.90	16.00	
1 "	x	3.175	TMSC 16159-N- 8" UN	6	92	12 - 38.100	15.90	16.00	
1 1/8 " - 1 1/4 "	x	3.628	TMSC 16159-N- 7" UN	6	92	10 - 36.285	15.90	16.00	
1 3/8 " - 1 1/2 "	x	4.233	TMSC 20199-N- 6" UN	6	104	9 - 38.100	19.90	20.00	
1 3/4 "	x	5.080	TMSC 20199-N- 5" UN	6	104	7 - 35.560	19.90	20.00	
2 "	x	5.644	TMSC 20199-N-4.5" UN	6	104	7 - 39.511	19.90	20.00	

UN 60° intérieur Pas Fin									
NORME		Référence Article	Z	L	Nb Filets / Lg coupe	Dc	D	Tarif	
5 / 16 "	x	0.794	TMSC 06059-N-32 " UN	5	57	18 - 14.287	5.90	6.0	
7 / 16 "	x	0.907	TMSC 08079-N-28 " UN	5	63	22 - 19.950	7.90	8.0	
1 / 2 "	x	1.270	TMSC 10099-N-20 " UN	5	72	18 - 22.860	9.90	10.0	
9 / 16 "	x	1.410	TMSC 10099-N-18 " UN	5	72	17 - 23.980	9.90	10.0	Nous
5 / 8 "	x	1.587	TMSC 12119-N-16 " UN	5	83	18 - 28.575	11.90	12.0	
5 / 8 "	x	2.116	TMSC 12119-N-12 " UN	5	83	14 - 29.630	11.90	12.0	Consulter
1 "	x	3.175	TMSC 16159-N- 8 " UN	6	92	12 - 38.100	15.90	16.0	
1 3/8 "	x	4.233	TMSC 20199-N- 6 " UN	6	104	9 - 38.100	19.90	20.0	

UN 60° extérieur Pas Fin									
NORME		Référence Article	Z	L	Nb Filets / Lg coupe	Dc	D	Tarif	
N°6	x	0.794	TMSC 06059-E-32" UN	5	57	18 - 14.287	5.90	6.0	
N°12	x	0.906	TMSC 08079-E-28" UN	5	63	22 - 19.950	7.90	8.0	
1 / 4 "	x	1.270	TMSC 10099-E-20 " UN	5	72	18 - 22.860	9.90	10.0	
5 / 16 "	x	1.410	TMSC 10099-E-18" UN	5	72	17 - 23.980	9.90	10.0	Nous
3 / 8 "	x	1.587	TMSC 12119-E-16" UN	5	83	18 - 28.575	11.90	12.0	
9 / 16 "	x	2.116	TMSC 12119-E-12" UN	5	83	14 - 29.630	11.90	12.0	Consulter
1 "	x	3.175	TMSC 16159-E- 8" UN	6	92	12 - 38.100	15.90	16.0	
1 3/8 "	x	4.233	TMSC 20199-E- 6" UN	6	104	9 - 38.100	19.90	20.0	

■ Fraise à Fileter Carbone monobloc

BSW – BSP – BSPT – NPT – NPTF – PG

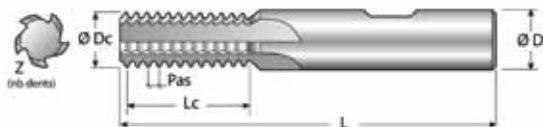

BSW 55° (British Standard Pipe Whitworth)							
NORME	Référence Article	Z	L	Nb Filets / Lg coupe	Dc	D	Tarif
3 / 32 " x 0.529	TMSC 03015-X-48" BSW	3	38	7 - 3.704	1.50	3.00	
1 / 8 " x 0.635	TMSC 03021-X-40" BSW	3	38	7 - 4.445	2.10	3.00	
5 / 32 " x 0.794	TMSC 03026-X-32" BSW	3	38	7 - 5.556	2.60	3.00	
1 / 4 " x 1.270	TMSC 06040-X-20" BSW	3	57	8 - 10.160	4.00	3.00	
5 / 16 " x 1.411	TMSC 06050-X-18" BSW	3	57	8 - 11.288	5.00	6.00	
3 / 8 " x 1.587	TMSC 06059-X-16" BSW	5	57	9 - 14.287	5.90	6.00	
7 / 16 " x 1.814	TMSC 08079-X-14" BSW	5	63	10 - 18.143	7.90	8.00	Nous
1/2" -9/16 " x 2.116	TMSC 08079-X-12" BSW	5	63	9 - 19.050	7.90	8.00	
5 / 8 " x 2.309	TMSC 10099-X-11" BSW	5	72	10 - 23.091	9.90	10.00	Consulter
3 / 4 " x 2.540	TMSC 12119-X-10" BSW	5	83	11 - 27.940	11.90	12.00	
7 / 8 " x 2.822	TMSC 12119-X- 9" BSW	5	83	10 - 28.222	11.90	12.00	
1 " x 3.175	TMSC 16159-X- 8" BSW	6	92	11 - 34.925	15.90	16.00	
1 1/8" - 1 1/4" x 3.628	TMSC 16159-X- 7" BSW	6	92	10 - 36.286	15.90	16.00	
1 3/8" - 1 1/2" x 4.233	TMSC 16159-X- 6" BSW	6	92	9 - 38.100	15.90	16.00	
1 3/8" - 1 3/4" x 5.080	TMSC 20199-X- 5" BSW	6	104	8 - 40.640	19.90	20.00	
1 1/8" - 2 " x 5.644	TMSC 20199-X-4.5" BSW	6	104	7 - 39.511	19.90	20.00	

BSP 55° (British Standard Pipe Parallel)							
NORME	Référence Article	Z	L	Nb Filets / Lg coupe	Dc	D	Tarif
1 / 16 " x 0.907	TMSC 06059-X-28" BSP	5	57	16 - 14.514	5.90	6.00	Nous
1 / 4 " x 1.337	TMSC 08079-X-19" BSP	5	63	14 - 18.716	7.90	8.00	
1 / 2 " x 1.814	TMSC 12119-X-14" BSP	5	83	16 - 29.028	11.90	12.00	Consulter
1 " x 2.309	TMSC 16159-X-11" BSP	6	92	15 - 34.636	15.90	16.00	

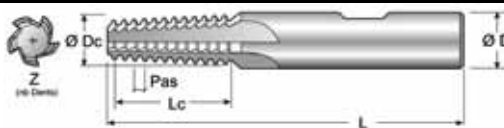

BSPT 55° Taper 1/16" (British Standard Pipe Tapered)							
NORME	Référence Article	Z	L	Nb Filets / Lg coupe	Dc	D	Tarif
1 / 16 " x 0.907	TMSC 06059-X-28" BSPT	5	57	11 - 9.978	5.90	6.00	Nous
1 / 4 " x 1.337	TMSC 08079-X-19" BSPT	5	63	11 - 14.705	7.90	8.00	
1 / 2 " x 1.814	TMSC 12119-X-14" BSPT	5	83	11 - 19.957	11.90	12.00	Consulter
1 " x 2.309	TMSC 16159-X-11" BSPT	6	92	17 - 39.250	15.90	16.00	

NPT 60° (National Pipe Taper)							
NORME	Référence Article	Z	L	Nb Filets / Lg coupe	Dc	D	Tarif
1 / 16 " x 0.941	TMSC 06059 -X- 27" NPT	5	57	10 - 9.407	5.90	6.00	
1 / 4 " x 1.411	TMSC 08079 -X- 18" NPT	5	63	10 - 14.111	7.90	8.00	
1 / 2 " x 1.814	TMSC 12119 -X- 14" NPT	5	83	11 - 19.957	11.90	12.00	Nous
1 " x 2.209	TMSC 16159-X-11.5" NPT	6	92	12 - 26.505	15.90	16.00	
2 1/2 " x 3.175	TMSC 16159 -X- 8" NPT	6	92	10 - 31.750	15.90	16.00	Consulter
2 1/2 " x 3.175	TMSC 20199 -X- 8" NPT	6	104	12 - 38.100	19.90	20.00	

NPTF 60° (National Pipe Taper Dryseal)							
NORME	Référence Article	Z	L	Nb Filets / Lg coupe	Dc	D	Tarif
1 / 16 " x 0.941	TMSC 06059 -X- 27" NPTF	5	57	10 - 9.407	5.90	6.00	
1 / 4 " x 1.411	TMSC 08079 -X- 18" NPTF	5	63	10 - 14.111	7.90	8.00	
1 / 2 " x 1.814	TMSC 12119 -X- 14" NPTF	5	83	11 - 19.957	11.90	12.00	Nous
1 " x 2.209	TMSC 16159-X-11.5" NPTF	6	92	12 - 26.505	15.90	16.00	
2 1/2 " x 3.175	TMSC 16159 -X- 8" NPTF	6	92	10 - 31.750	15.90	16.00	Consulter
2 1/2 " x 3.175	TMSC 20199 -X- 8" NPTF	6	104	12 - 38.100	19.90	20.00	

PG 80°							
NORME	Référence Article	Z	L	Nb Filets / Lg coupe	Dc	D	Tarif
7	TMSC 08079 -X- 20" PG	5	63	15 - 19.050	7.90	8.00	Nous
9-11-13.5-16	TMSC 10099 -X- 18" PG	5	72	17 - 23.989	9.90	10.00	
21-29-36-42-48	TMSC 12119 -X- 16" PG	5	83	18 - 28.575	11.90	12.00	Consulter

■ Fraise à Fileter T2 - T3

ISO & UN Carbure monobloc

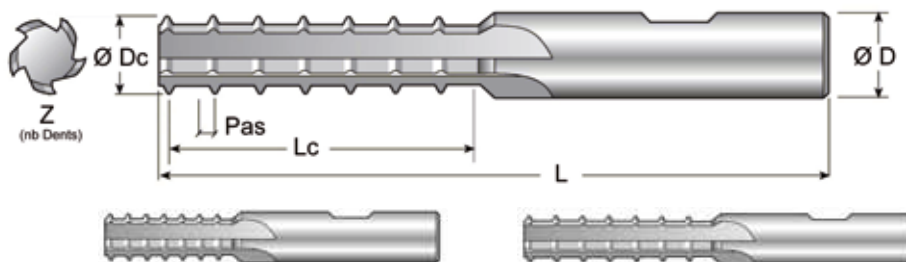

					T2 - ISO à 60°			T3 - ISO à 60°				
NORME	Z	Dc	D	Référence Article	L	Nb Filets / Lg coupe		Référence Article	L	Nb Filets / Lg coupe		Tarif
M 4 x 0.70	3	2.60	3	TMN 03026-N-0.70 ISO-T2	38	12 - 8.40		TMN 03026-N-0.70 ISO-T3	38	18 - 12.60		
M 5 x 0.80	3	3.60	4	TMN 04036-N-0.80 ISO-T2	63	14 - 11.20		TMN 04036-N-0.80 ISO-T3	63	22 - 17.60		Nous
M 6 x 1.00	3	4.00	6	TMN 06040-N-1.00 ISO-T2	72	12 - 12.00		TMN 06040-N-1.00 ISO-T3	63	18 - 18.00		
M 8 x 1.25	3	5.00	6	TMN 06050-N-1.25 ISO-T2	72	14 - 17.50		TMN 06050-N-1.25 ISO-T3	72	21 - 26.25		Consulter
M 10 x 1.50	5	5.90	6	TMN 06059-N-1.50 ISO-T2	72	14 - 21.00		TMN 06059-N-1.50 ISO-T3	72	21 - 31.50		
M 12 x 1.75	5	7.90	8	TMN 08079-N-1.75 ISO-T2	83	14 - 24.50		TMN 08079-N-1.75 ISO-T3	83	21 - 36.75		
M 14 x 2.00	5	9.90	10	TMN 10099-N-2.00 ISO-T2	83	14 - 28.00		TMN 10099-N-2.00 ISO-T3	83	21 - 42.00		
M 16 x 2.00	5	11.90	12	TMN 12119-N-2.00 ISO-T2	104	16 - 32.00		TMN 12119-N-2.00 ISO-T3	100	24 - 48.00		
M 20 x 2.50	5	11.90	12	TMN 12119-N-2.50 ISO-T2	104	16 - 40.00		TMN 12119-N-2.50 ISO-T3	100	20 - 50.00		



					T2 - ISO Pas Fin à 60°			T3 - ISO Pas Fin à 60°				
NORME	Z	Dc	D	Référence Article	L	Nb Filets / Lg coupe		Référence Article	L	Nb Filets / Lg coupe		Tarif
M 8 x 0.75	5	5.90	6	TMN 06059-N-0.75 ISO-T2	72	26 - 19.50		TMN 06059-N-0.75 ISO-T3	72	39 - 29.25		
M 12 x 1.00	5	7.90	8	TMN 08079-N-1.00 ISO-T2	83	24 - 24.00		TMN 08079-N-1.00 ISO-T3	83	36 - 36.00		Nous
M 14 x 1.50	5	9.90	10	TMN 10099-N-1.50 ISO-T2	83	22 - 33.00		TMN 10099-N-1.50 ISO-T3	83	28 - 42.00		
M 16 x 1.00	5	11.90	12	TMN 12119-N-1.00 ISO-T2	100	46 - 46.00		TMN 12119-N-1.00 ISO-T3	104	51 - 51.00		Consulter
M 16 x 2.00	5	11.90	12	TMN 12119-N-2.00 ISO-T2	100	22 - 44.00		TMN 12119-N-2.00 ISO-T3	100	24 - 48.00		
M 18 x 1.50	5	11.90	12	TMN 12119-N-1.50 ISO-T2	100	30 - 45.00		TMN 12119-N-1.50 ISO-T3	100	33 - 49.50		



					T2 - UN à 60°			T3 - UN à 60°				
NORME	Z	Dc	D	Référence Article	L	Nb Filets / Lg coupe		Référence Article	L	Nb Filets / Lg coupe		Tarif
N°4 x 0.635	3	2.10	3	TMSC 03021-N- 40 " UN T2	38	10 - 6.350		TMSC 03021-N- 40 " UN T3	38	15 - 9.525		
N°8 x 0.705	3	3.00	4	TMSC 04030-N- 36 " UN T2	65	12 - 8.466		TMSC 04030-N- 36 " UN T3	65	18 - 12.700		
N°8 x 0.794	3	3.00	4	TMSC 04030-N- 32 " UN T2	65	12 - 9.525		TMSC 04030-N- 32 " UN T3	65	18 - 14.287		
1/4 " x 1.270	3	4.00	6	TMSC 06040-N- 20 " UN T2	75	10 - 12.700		TMSC 06040-N- 20 " UN T3	75	15 - 19.050		
5/16" x 1.411	3	5.00	6	TMSC 06050-N- 18 " UN T2	75	12 - 16.933		TMSC 06050-N- 18 " UN T3	75	18 - 25.400		
3/8 " x 1.587	5	5.90	6	TMSC 06059-N- 16 " UN T2	75	12 - 19.050		TMSC 06059-N- 16 " UN T3	75	18 - 28.575		Nous
7/16" x 1.814	5	7.90	8	TMSC 08079-N- 14 " UN T2	85	14 - 25.400		TMSC 08079-N- 14 " UN T3	85	21 - 38.100		
1/2 " x 1.954	5	7.90	8	TMSC 08079-N- 13 " UN T2	85	14 - 27.354		TMSC 08079-N- 13 " UN T3	85	21 - 41.031		Consulter
9/16" x 2.116	5	9.90	10	TMSC 10099-N- 12 " UN T2	85	14 - 29.633		TMSC 10099-N- 12 " UN T3	85	21 - 44.450		
5/8 " x 2.309	5	11.90	12	TMSC 10099-N- 11 " UN T2	100	14 - 32.327		TMSC 10099-N- 11 " UN T3	100	19 - 43.872		
3/4 " x 2.540	5	11.90	12	TMSC 12119-N- 10 " UN T2	100	16 - 40.640		TMSC 12119-N- 10 " UN T3 *	100	20 - 50.800		
7/8 " x 2.822	6	15.90	16	TMSC 12119-N- 9 " UN T2	104	16 - 45.156		-	-	-		
1 " x 3.175	6	15.90	16	TMSC 16159-N- 8 " UN T2	104	16 - 50.800		-	-	-		

■ Fraise à Fileter

Carbure monobloc à Alésage

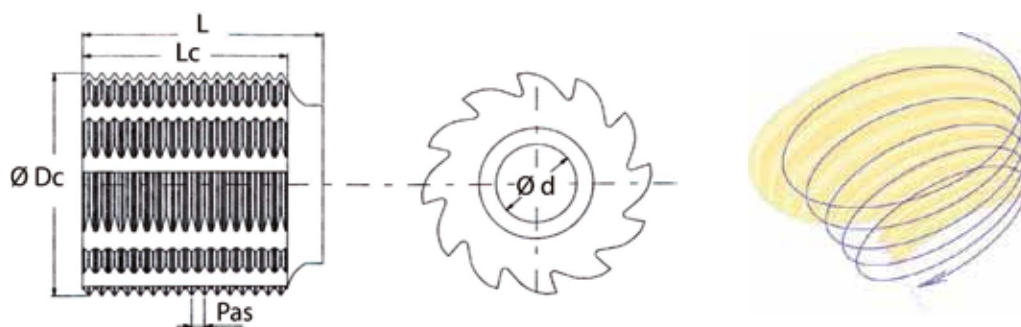

ISO & UN 60° - Ø 35

NORME	Référence Article	Z	L	Nb Filets / Lg coupe	Dc	D	Tarif
M 48 x 1.50	TMSC 350-N-1.50 ISO	12	38	20 - 30.0	35	13	
M 48 x 2.00	TMSC 350-N-2.00 ISO	12	38	15 - 30.0	35	13	
M 48 x 3.00	TMSC 350-N-3.00 ISO	12	38	10 - 30.0	35	13	
M 48 x 4.00	TMSC 350-N-4.00 ISO	12	38	7 - 28.0	35	13	Nous
1 3/4" x 1.269	TMSC 350- N -20" UN	12	38	23 - 29.2	35	13	Consulter
1 3/4" x 1.409	TMSC 350- N -18" UN	12	38	21 - 29.6	35	13	
1 3/4" x 1.589	TMSC 350- N -16" UN	12	38	18 - 28.6	35	13	
1 3/4" x 2.114	TMSC 350- N -12" UN	12	38	14 - 29.6	35	13	
1 3/4" x 3.177	TMSC 350- N - 8" UN	12	38	9 - 28.6	35	13	
1 3/4" x 4.228	TMSC 350- N - 6" UN	12	38	7 - 29.6	35	13	

ISO & UN 60° - Ø 45

NORME	Référence Article	Z	L	Nb Filets / Lg coupe	Dc	D	Tarif
M 56 x 1.50	TMSC 450-N-1.50 ISO	12	47	29 - 39.0	45	16	
M 56 x 2.00	TMSC 450-N-2.00 ISO	12	47	20 - 40.0	45	16	
M 56 x 3.00	TMSC 450-N-3.00 ISO	12	47	13 - 39.0	45	16	
M 56 x 4.00	TMSC 450-N-4.00 ISO	12	47	10 - 40.0	45	16	
M 56 x 5.50	TMSC 450-N-5.50 ISO	12	47	7 - 38.5	45	16	
M 64 x 6.00	TMSC 450-N-6.00 ISO	12	47	6 - 36.0	45	16	Nous
2 1/2" x 1.271	TMSC 450- N -20" UN	12	47	31 - 39.4	45	16	Consulter
2 1/2" x 1.588	TMSC 450- N -16" UN	12	47	25 - 39.7	45	16	
2 1/2" x 2.116	TMSC 450- N - 12" UN	12	47	18 - 38.1	45	16	
2 1/2" x 3.175	TMSC 450- N - 8" UN	12	47	12 - 38.1	45	16	
2 1/2" x 4.233	TMSC 450- N - 6" UN	12	47	9 - 38.1	45	16	
2 1/4" x 5.643	TMSC 450- N -4.5" UN	12	47	7 - 39.5	45	16	
2 1/2" x 6.350	TMSC 450- N - 4" UN	12	47	6 - 38.1	45	16	

ISO & UN 60° - Ø 55

NORME	Référence Article	Z	L	Nb Filets / Lg coupe	Dc	D	Tarif
M 64 x 1.50	TMSC 550-N-1.50 ISO	12	58	33 - 49.5	55	22	
M 64 x 2.00	TMSC 550-N-2.00 ISO	12	58	25 - 50.0	55	22	
M 64 x 3.00	TMSC 550-N-3.00 ISO	12	58	16 - 48.0	55	22	
M 64 x 4.00	TMSC 550-N-4.00 ISO	12	58	12 - 48.0	55	22	Nous
M 64 x 6.00	TMSC 550-N-6.00 ISO	12	58	8 - 48.0	55	22	
2 3/4" x 1.269	TMSC 550- N -20" UN	12	58	39 - 49.5	55	22	Consulter
2 3/4" x 1.587	TMSC 550- N -16" UN	12	58	31 - 49.2	55	22	
2 3/4" x 2.117	TMSC 550- N -12" UN	12	58	23 - 48.7	55	22	
2 3/4" x 3.173	TMSC 550- N - 8" UN	12	58	15 - 47.6	55	22	
2 3/4" x 4.236	TMSC 550- N - 6" UN	12	58	11 - 46.6	55	22	
2 3/4" x 6.357	TMSC 550- N - 4" UN	12	58	7 - 44.5	55	22	

■ Plaquette carbure indexable

Pour Fraise à Fileter ISO & UN 60°

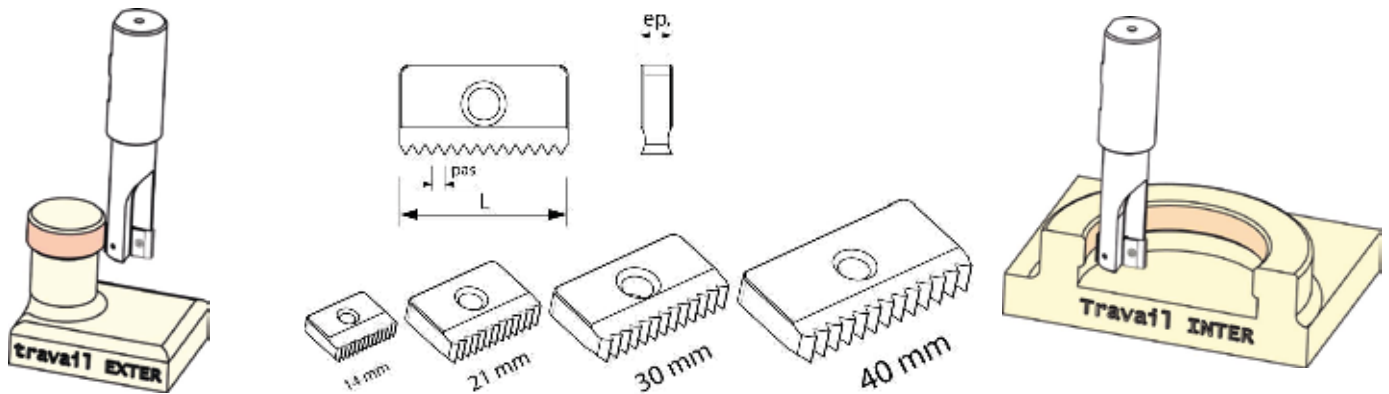

Travail EXTERIEUR	
Référence Article	
14-ETM-1.00 ISO	
21-ETM-1.00 ISO	
14-ETM-1.50 ISO	
21-ETM-1.50 ISO	
30-ETM-1.50 ISO	
14-ETM-2.00 ISO	
21-ETM-2.00 ISO	
30-ETM-2.00 ISO	
21-ETM-2.50 ISO	
30-ETM-2.50 ISO	
21-ETM-3.00 ISO	
30-ETM-3.00 ISO	
21-ETM-3.50 ISO	
30-ETM-3.50 ISO	
30-ETM-4.00 ISO	
40-ETM-4.00 ISO	
40-ETM-5.00 ISO	
40-ETM-6.00 ISO	

Pass	L	Nb Filets	Centrage	Porte-Outil	Tarif
1.00	14	14	0	TMH.....-14	
1.00	21	21	0	TMH.....-21	
1.50	14	9	0.25	TMH.....-14	
1.50	21	14	0	TMH.....-21	
1.50	30	20	0	TMH.....-30	
2.00	14	7	0	TMH.....-14	Nous
2.00	21	10	0.50	TMH.....-21	
2.00	30	15	0	TMH.....-30	Consulter
2.50	21	8	0.5	TMH.....-21	
2.50	30	12	0	TMH.....-30	
3.00	21	7	0	TMH.....-21	
3.00	30	10	0	TMH.....-30	
3.50	21	6	0	TMH.....-21	
3.50	30	8	1	TMH.....-30	
4.00	30	7	1	TMH.....-30	
4.00	40	10	0	TMH.....-40	
5.00	40	8	0	TMH.....-40	
6.00	40	6	2	TMH.....-40	

Travail Intérieur	
Référence Article	
14-NTM-1.00 ISO	
21-NTM-1.00 ISO	
14-NTM-1.50 ISO	
21-NTM-1.50 ISO	
30-NTM-1.50 ISO	
14-NTM-2.00 ISO	
21-NTM-2.00 ISO	
30-NTM-2.00 ISO	
21-NTM-2.50 ISO	
30-NTM-2.50 ISO	
21-NTM-3.00 ISO	
30-NTM-3.00 ISO	
21-NTM-3.50 ISO	
30-NTM-3.50 ISO	
30-NTM-4.00 ISO	
40-NTM-4.00 ISO	
40-NTM-5.00 ISO	
40-NTM-6.00 ISO	

Travail Extérieur	
Référence Article	
14-ETM-48"UN	
14-ETM-40"UN	
14-ETM-32"UN	
14-ETM-28"UN	
14-ETM-27"UN	
14-ETM-24"UN	
14-ETM-20"UN	
21-ETM-20"UN	
14-ETM-18"UN	
21-ETM-18"UN	
30-ETM-18"UN	
40-ETM-18"UN	
14-ETM-16"UN	
21-ETM-16"UN	
30-ETM-16"UN	
40-ETM-16"UN	
14-ETM-14"UN	
21-ETM-14"UN	
30-ETM-14"UN	
40-ETM-14"UN	
14-ETM-12"UN	
21-ETM-12"UN	
30-ETM-12"UN	
40-ETM-12"UN	
21-ETM-10"UN	
30-ETM-10"UN	
40-ETM-10"UN	
21-ETM-9"UN	
30-ETM-9"UN	
40-ETM-9"UN	
21-ETM-8"UN	
30-ETM-8"UN	
40-ETM-8"UN	
30-ETM-7"UN	
40-ETM-7"UN	
30-ETM-6"UN	
40-ETM-6"UN	
30-ETM-5"UN	
40-ETM-5"UN	
40-ETM-4.5"UN	
40-ETM-4"UN	
40-ETM-3.5"UN	

Pass	L	Nb Filets	Centrage	Porte-Outil	Tarif
48"	14	26	0.121	TMH.....-14	
40"	14	22	0.015	TMH.....-14	
32"	14	17	0.253	TMH.....-14	
28"	14	15	0.196	TMH.....-14	
27"	14	14	0.415	TMH.....-14	
24"	14	13	0.121	TMH.....-14	Nous
20"	14	11	0.015	TMH.....-14	
20"	21	16	0.340	TMH.....-21	Consulter
18"	14	11	0.650	TMH.....-14	
18"	21	14	0.622	TMH.....-21	
18"	30	21	0.183	TMH.....-30	
18"	40	28	0.244	TMH.....-40	
16"	14	8	0.650	TMH.....-14	
16"	21	13	0.181	TMH.....-21	Nous
16"	30	18	0.712	TMH.....-30	
16"	40	25	0.156	TMH.....-40	Consulter
14"	14	8	-0.257	TMH.....-14	
14"	21	11	0.521	TMH.....-21	
14"	30	16	0.486	TMH.....-30	
14"	40	22	0.043	TMH.....-40	
12"	14	6	0.650	TMH.....-14	
12"	21	9	0.975	TMH.....-21	
12"	30	14	0.183	TMH.....-30	
12"	40	18	0.950	TMH.....-40	Nous
10"	21	8	0.340	TMH.....-21	
10"	30	11	1.030	TMH.....-30	Consulter
10"	40	14	0.950	TMH.....-40	
9"	21	7	0.622	TMH.....-21	
9"	30	10	0.889	TMH.....-30	
9"	40	14	0.244	TMH.....-40	
8"	21	6	0.975	TMH.....-21	
8"	30	9	0.713	TMH.....-30	
8"	40	12	0.950	TMH.....-40	
7"	30	8	0.486	TMH.....-30	
7"	40	11	0.043	TMH.....-40	
6"	30	7	0.183	TMH.....-30	Nous
6"	40	9	0.950	TMH.....-40	
5"	30	6	-0.240	TMH.....-30	Consulter
5"	40	8	-0.320	TMH.....-40	
4.5"	40	7	0.244	TMH.....-40	
4"	40	6	0.950	TMH.....-40	
3.5"	40	5	1.857	TMH.....-40	

Travail Intérieur	
Référence Article	
14-NTM-48"UN	
14-NTM-40"UN	
14-NTM-32"UN	
14-NTM-28"UN	
14-NTM-27"UN	
14-NTM-24"UN	
14-NTM-20"UN	
21-NTM-20"UN	
14-NTM-18"UN	
21-NTM-18"UN	
30-NTM-18"UN	
40-NTM-18"UN	
14-NTM-16"UN	
21-NTM-16"UN	
30-NTM-16"UN	
40-NTM-16"UN	
14-NTM-14"UN	
21-NTM-14"UN	
30-NTM-14"UN	
40-NTM-14"UN	
14-NTM-12"UN	
21-NTM-12"UN	
30-NTM-12"UN	
40-NTM-12"UN	
21-NTM-10"UN	
30-NTM-10"UN	
40-NTM-10"UN	
21-NTM-9"UN	
30-NTM-9"UN	
40-NTM-9"UN	
21-NTM-8"UN	
30-NTM-8"UN	
40-NTM-8"UN	
30-NTM-7"UN	
40-NTM-7"UN	
30-NTM-6"UN	
40-NTM-6"UN	
30-NTM-5"UN	
40-NTM-5"UN	
40-NTM-4.5"UN	
40-NTM-4"UN	
40-NTM-3.5"UN	

■ Plaque carbure indexable pour Filetage

BSP – NPSM – NPSF – BSPT – NPT – NPTF

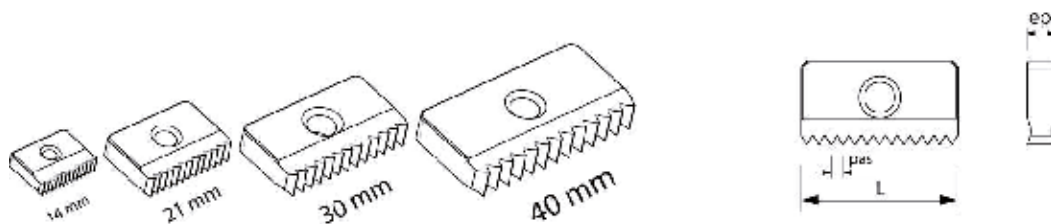

BSP à 55°

Pas	Référence Article	L	Nb Filets	Centrage	Porte-Outil	Tarif
19"	14-XTM-19" BSP	14	10	0.316	TMH. -14	
14"	14-XTM-14" BSP	14	7	0.650	TMH. -14	Nous
14"	21-XTM-14" BSP	21	11	0.521	TMH. -21	
14"	30-XTM-14" BSP	30	16	0.486	TMH. -30	Consulter
11"	21-XTM-11" BSP	21	9	0.109	TMH. -21	
11"	30-XTM-11" BSP	30	13	0.009	TMH. -30	
11"	40-XTM-11" BSP	40	17	0.373	TMH. -40	

NPSM à 60°

Pas	Référence Article	L	Nb Filets	Centrage	Porte-Outil	Tarif
18"	14-XTM-18" NPSM	14	9	0.650	TMH. -14	
14"	14-XTM-14" NPSM	14	7	0.650	TMH. -14	Nous
14"	21-XTM-14" NPSM	21	11	0.521	TMH. -21	
11.5"	21-XTM-11.5" NPSM	21	9	0.561	TMH. -21	Consulter
11.5"	30-XTM-11.5" NPSM	30	13	0.643	TMH. -30	
8"	30-XTM-8" NPSM	30	9	0.712	TMH. -30	

NPSF à 60°

Pas	Référence Article	L	Nb Filets	Centrage	Porte-Outil	Tarif
18"	14-XTM-18" NPSF	14	9	0.650	TMH. -14	
14"	14-XTM-14" NPSF	14	7	0.650	TMH. -14	Nous
14"	21-XTM-14" NPSF	21	11	0.521	TMH. -21	
11.5"	21-XTM-11.5" NPSF	21	9	0.561	TMH. -21	Consulter
11.5"	30-XTM-11.5" NPSF	30	13	0.643	TMH. -30	
8"	30-XTM-8" NPSF	30	9	0.712	TMH. -30	

BSPT à 55° Taper 1 :16

Pas	Référence Article	L	Nb Filets	Centrage	Porte-Outil	Tarif
19"	14-XTM-19" BSPT-S	14	10	0.316	TMH. -14	
14"	14-XTM-14" BSPT-S	14	7	0.650	TMH. -14	
14"	21-XTM-14" BSPT-S	21	11	0.521	TMH. -21	
14"	30-XTM-14" BSPT-S	30	16	0.486	TMH. -30	Nous
11"	21-XTM-11" BSPT-S	21	9	0.109	TMH. -21	
11"	30-XTM-11" BSPT-S	30	13	0.009	TMH. -30	Consulter
11"	40-XTM-11" BSPT-S	40	17	0.373	TMH. -40	

NPT à 60° Taper 1 :16

Pas	Référence Article	L	Nb Filets	Centrage	Porte-Outil	Tarif
18"	14-XTM-18" NPT-SXP	14	9	0.650	TMH. -14 T	
18"	21-XTM-18" NPT-SXP	21	14	0.622	TMH. -21 T	
14"	14-XTM-14" NPT-SXP	14	7	0.650	TMH. -14 T	
14"	21-XTM-14" NPT-SXP	21	11	0.521	TMH. -21 T	Nous
11.5"	21-XTM-11.5" NPT-SXP	21	9	0.561	TMH. -21	
11.5"	30-XTM-11.5" NPT-SXP	30	13	0.643	TMH. -30	Consulter
11.5"	40-XTM-11.5" NPT-SXP	40	18	0.122	TMH. -40	
8"	30-XTM-8" NPT-SXP	30	9	0.712	TMH. -30	
8"	40-XTM-8" NPT-SXP	40	12	0.950	TMH. -40	

NPTF à 60° Taper 1 :16

Pas	Référence Article	L	Nb Filets	Centrage	Porte-Outil	Tarif
18"	14-XTM-18" NPTF-SXP	14	9	0.650	TMH. -14 T	
18"	21-XTM-18" NPTF-SXP	21	14	0.622	TMH. -21 T	
14"	14-XTM-14" NPTF-SXP	14	7	0.650	TMH. -14 T	
14"	21-XTM-14" NPTF-SXP	21	11	0.521	TMH. -21 T	Nous
11.5"	21-XTM-11.5" NPTF-SXP	21	9	0.561	TMH. -21	
11.5"	30-XTM-11.5" NPTF-SXP	30	13	0.643	TMH. -30	Consulter
11.5"	40-XTM-11.5" NPTF-SXP	40	18	0.122	TMH. -40	
8"	30-XTM-8" NPTF-SXP	30	9	0.712	TMH. -30	
8"	40-XTM-8" NPTF-SXP	40	12	0.950	TMH. -40	

Fraise à fileter QC

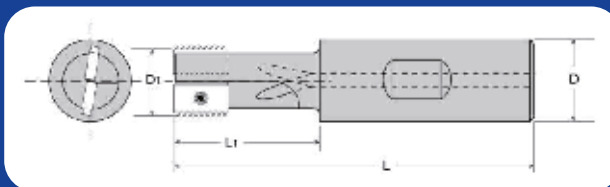

Plaquette	Référence Article	Z	L	L1	D	Dc	Tarif
TM 14	TMH02012-1-14	1	75	20	20	12	
TM 14	TMH02017-1-14	1	85	30	20	17	
TM 21	TMH02020-1-21	1	93	40	20	20	
TM 30	TMH02529-1-30	1	108	5	25	29	Nous
TM 30	TMH03238-1-30	1	130	70	32	38	
TM 40	TMH04044-1-40	1	153	82	40	44	Consulter
TM 14	TMH02020-2-14	2	93	40	20	20	
TM 21	TMH02530-2-21	2	108	50	25	30	
TM 30	TMH03240-2-30	2	130	70	32	40	
TM 40	TMH04050-2-40	2	153	82	40	50	

Fraise à fileter à Alésage

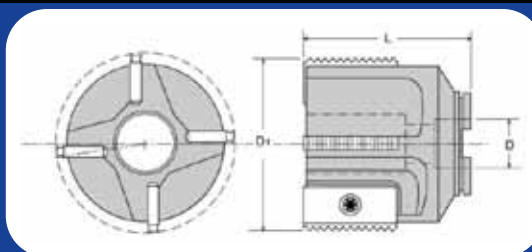

Plaquette	Référence Article	Z	L	L1	D	Dc	Tarif
TM 30	TMH06322-4-30	4	50	30	22	63	
TM 30	TMH08027-4-30	4	55	30	27	80	Nous
TM 40	TMH08027-4-40	4	65	40	27	80	
TM 30	TMH10032-5-30	5	60	30	32	100	Consulter
TM 40	TMH10032-5-40	5	70	40	32	100	

Accessoires



Plaquette	Référence Article	Clef Torx	Ref Clef torx	Tarif	Vis torx	Ref Vis	Tarif
TM 14	TMH02012-1-14	n°7	263490		M 2.5 x 6	60F2506T	
TM 14	TMH02017-1-14	n°7	263490		M 2.5 x 6	60F2506T	
TM 21	TMH02020-1-21	n°20	263994		M 4 x 10	60F4010T	
TM 30	TMH02529-1-30	n°20	263994	Nous	M 5 x 12	60F5012T	Nous
TM 30	TMH03238-1-30	n°20	263994		M 5 x 12	60F5012T	
TM 40	TMH04044-1-40	n°20	263994	Consulter	M 5 x 12	60F5012T	Consulter
TM 14	TMH02020-2-14	n°7	263490		M 2.5 x 6	60F2506T	
TM 21	TMH02530-2-21	n°20	263994		M 4 x 10	60F4010T	
TM 30	TMH03240-2-30	n°20	263994		M 5 x 12	60F5012T	
TM 40	TMH04050-2-40	n°20	263994		M 5 x 12	60F5012T	
TM 30	TMH06322-4-30	n°20	263994		M 5 x 12	60F5012T	
TM 30	TMH08027-4-30	n°20	263994		M 5 x 12	60F5012T	
TM 40	TMH08027-4-40	n°20	263994		M 5 x 12	60F5012T	
TM 30	TMH10032-5-30	n°20	263994		M 5 x 12	60F5012T	
TM 40	TMH10032-5-40	n°20	263994		M 5 x 12	60F5012T	

evatec tools®

Solutions sur mesure pour votre usinage
Machining solutions especially for you

CARBURE



PCBN / PCD



AÉRONAUTIQUE



TOURNAGE



USINAGE DE TROUS

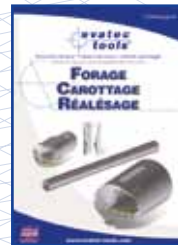

ATTACHEMENTS

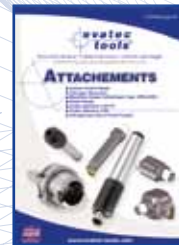

FRAISAGE

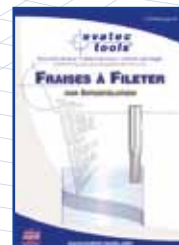
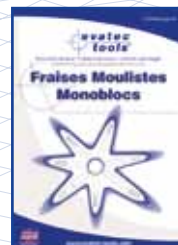

MÉTIERS / SPÉCIFIQUES

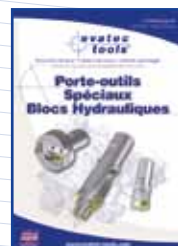

Téléchargez nos catalogues sur www.evatec-tools.com

Download our CATALOGS on www.evatec-tools.com

evatools® evamet® carbex® gmo®
coriatec® create outillage®

12, rue des Terres Rouges - Z.I. Metzange - 57100 Thionville
Tél. : 03 82 88 61 61 - E-mail : evatec@evatec-tools.fr

www.evatec-tools.com

