

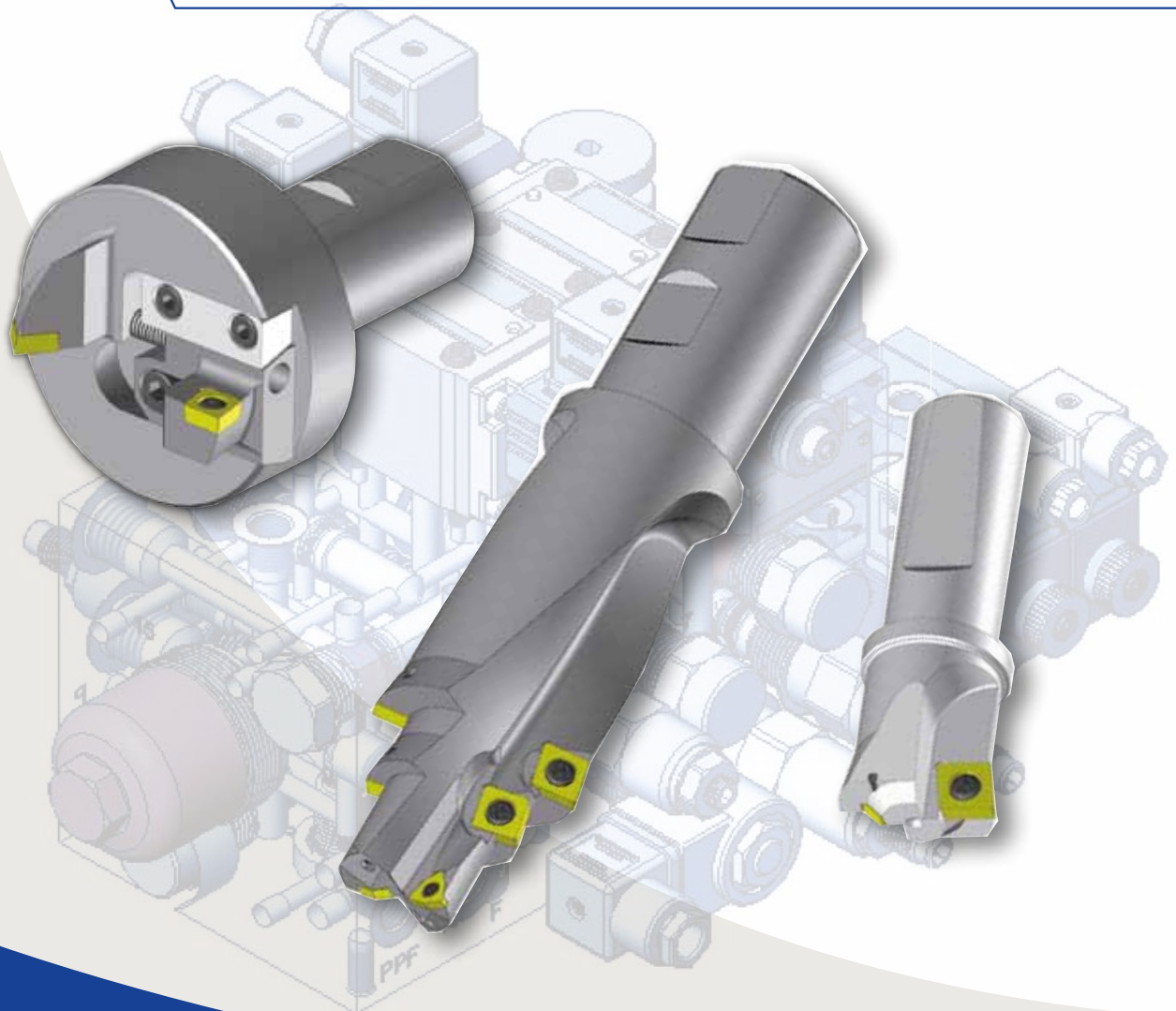

Solutions sur mesure pour votre usinage
Machining solutions especially for you

PORTE-OUTILS SPÉCIAUX

Blocs Hydrauliques



Sommaire

■ Raccords

- Porte-Outils pour raccords RBM & BNM **Page 03**
- Porte-Outils pour raccords Gaz **Page 04**
- Porte-Outils pour raccords Gaz réglables **Page 05**
- Porte-Outils pour raccords Staubli **Page 06**

■ Porte-outils Combiné d'Ebauche

- Porte-outil combiné avec Percage **Page 07**
- Porte-Outil à lamer d'ébauche combiné pour clapet **Page 08**
- Porte-Outil à lamer-chanfreiner combiné pour clapet **Page 09**

■ Porte-outils de Finition

- Barre d'alésage **Page 10**
- Barre de finition à réglage micrométrique **Page 11**

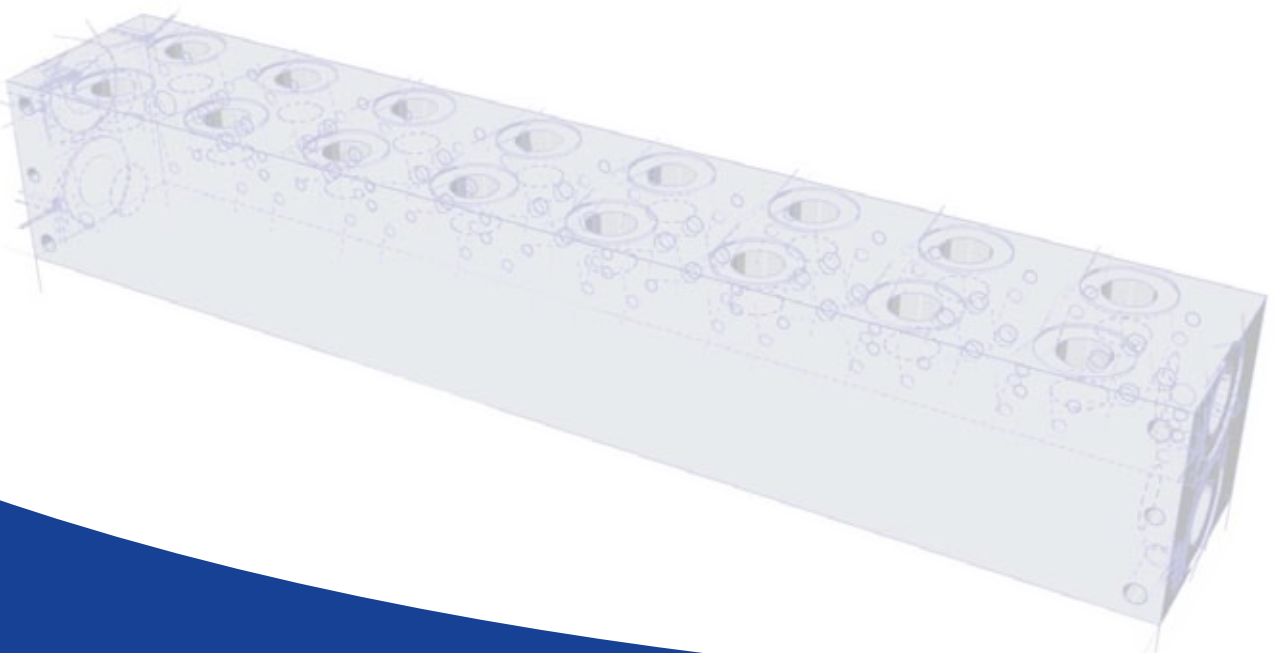

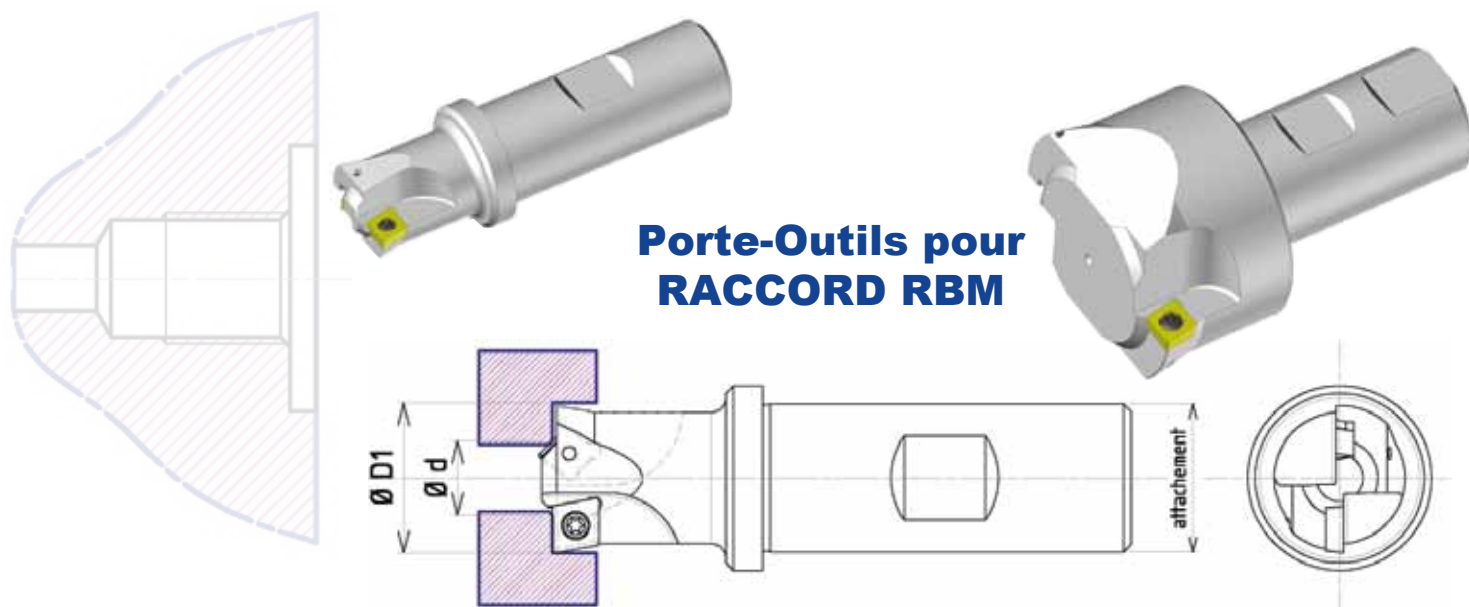

Porte-Outils pour RACCORD RBM

RBM	Code G.M.O	Ø D1 ⁺²	Ø d	Plaquette	Attachement
M 10 x 100	37400193	20	10	1 CCMT 06-02-04 + 1 CPGT 05-02-04	QC Ø 20
M 12 x 150	37400194	25	12	1 CCMT 08-03-04 + 1 CPGT 05-02-04	QC Ø 20
M 14 x 150	37400195	25	14	1 CCMT 08-03-04 + 1 CPGT 05-02-04	QC Ø 20
M 16 x 150	37400196	28	16	1 CCMT 08-03-04 + 1 CPGT 05-02-04	QC Ø 20
M 18 x 150	37400197	30	18	1 CCMT 08-03-04 + 1 CPGT 05-02-04	QC Ø 25
M 20 x 150	37400198	34	20	1 CCMT 09-T3-04 + 1 CCMT 06-02-04	QC Ø 25
M 22 x 150	37400199	34	22	1 CCMT 09-T3-04 + 1 CCMT 06-02-04	QC Ø 25
M 27 x 200	37400200	42	27	1 CCMT 09-T3-04 + 1 CCMT 06-02-04	QC Ø 32
M 33 x 200	37400201	47	33	1 CCMT 09-T3-04 + 1 CCMT 06-02-04	QC Ø 32
M 42 x 200	37400202	58	42	1 CCMT 09-T3-04 + 1 CCMT 06-02-04	QC Ø 32
M 48 x 200	37400203	65	48	1 CCMT 09-T3-04 + 1 CCMT 06-02-04	QC Ø 32

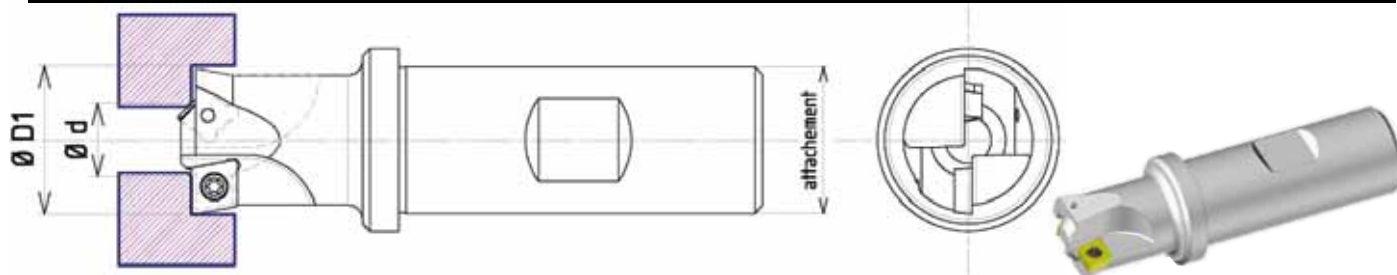

Porte-Outils pour RACCORD BNM

BNM	Code G.M.O	Ø D1 ⁺²	Ø d	Plaquette	Attachement
M 8 x 100	37400818	13	8	2 CPGT 04-T1-04	QC Ø 20
M 10 x 100	37400204	15	10	2 CPGT 04-T1-04	QC Ø 20
M 12 x 150	37400205	18	12	2 CPGT 04-T1-04	QC Ø 20
M 18 x 150	37400206	25	18	2 CPGT 05-02-04	QC Ø 20
M 22 x 150	37400207	28	22	1 CPGT 05-02-04 + 1 CCMT 06-02-04	QC Ø 25

■ Porte-Outils pour raccords Gaz

Porte-Outils à Lamer / Chanfreiner

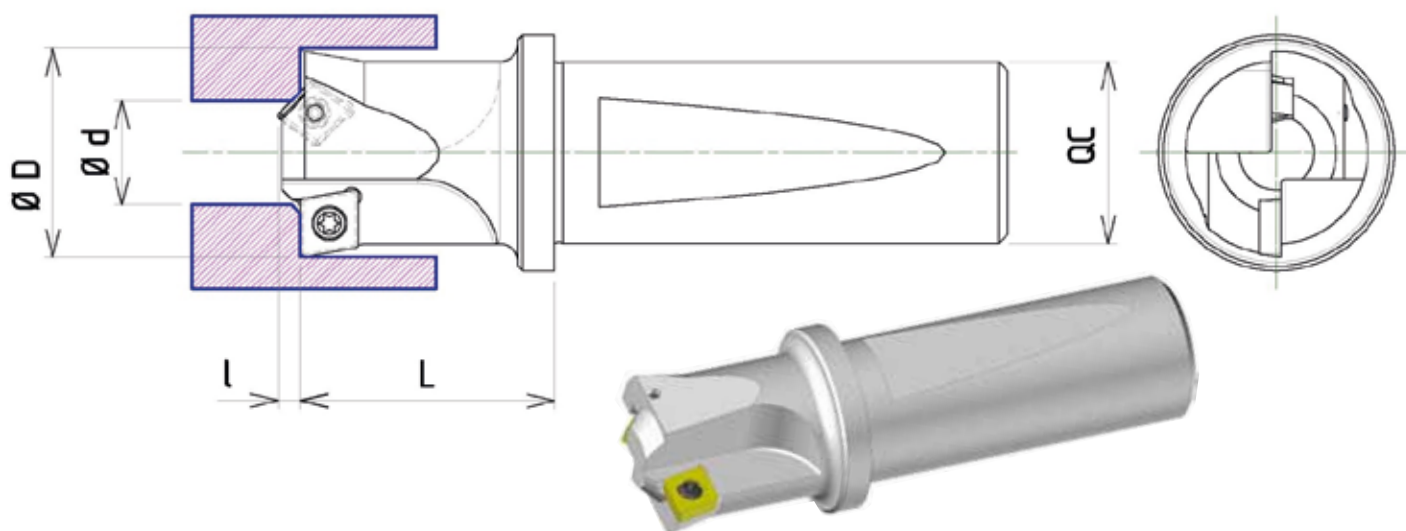

Raccord Gaz	Code G.M.O	Ø D	Ø d	L	l	Plaquette	Attachement
1/8 G	37400494	16	10	28	2.25	2 CPGT 04-T1-04	QC Ø 20
	37400540	20	10,2	30	2	1 CCMT 06-02-04 + 1 CPGT 05-02-04	QC Ø 20
1/4 G	37400176	20	13.4	28	2.5	1 CCMT 06-02-04 + 1 CPGT 05-02-04	QC Ø 20
	37400495	21	13.6	28	2.5	1 CCMT 06-02-04 + 1 CPGT 05-02-04	QC Ø 20
	37400150	23	13.4	28	2.5	1 CCMT 06-02-04 + 1 CPGT 05-02-04	QC Ø 20
	37400541	25.2	13.6	28	2	1 CCMT 09-T3-08 + 1 CCMT 06-02-04	QC Ø 25
3/8 G	37400151	28	17	32	2.65	1 CCMT 09-T3-08 + 1 CPGT 05-02-04	QC Ø 20
	37400177	23		28		1 CCMT 06-02-04 + 1 CPGT 05-02-04	QC Ø 20
1/2 G	37400152	33	21.3	32	2.75	1 CCMT 09-T3-08 + 1 CPGT 05-02-04	QC Ø 25
	37400418	33				1 CCMT 09-T3-08 + 1 CPGT 05-02-04	QC Ø 20
	37400497	29				1 CCMT 09-T3-08 + 1 CPGT 05-02-04	QC Ø 32
	37400178	28				1 CCMT 09-T3-08 + 1 CPGT 05-02-04	QC Ø 32
3/4 G	37400153	41	26.7	32	2.65	1 CCMT 09-T3-08 + 1 CPGT 05-02-04	QC Ø 32
	37400419	41				1 CCMT 09-T3-08 + 1 CPGT 05-02-04	QC Ø 20
	37400179	33				1 CCMT 09-T3-08 + 1 CPGT 05-02-04	QC Ø 32
1 G	37400219	51	33.6	32	2.75	1 CCMT 12-04-08 + 1 CPGT 05-02-04	QC Ø 32
	37400180	41		32		1 CCMT 09-T3-08 + 1 CPGT 05-02-04	QC Ø 32
1 G 1/4	37400430	51	42		3.25	2 CCMT 09-T3-08	QC Ø 32
	37400375	56				2 CCMT 09-T3-08	QC Ø 32
1 G 1/2	37400431	56	48		3.25	2 CCMT 09-T3-08	QC Ø 32
	37400376	62				2 CCMT 09-T3-08	QC Ø 32

■ Porte-Outils pour raccords Gaz Réglables

Exemples de porte-outils d'ébauche réglables

■ Porte-outil pour Raccord Gaz 1/4"

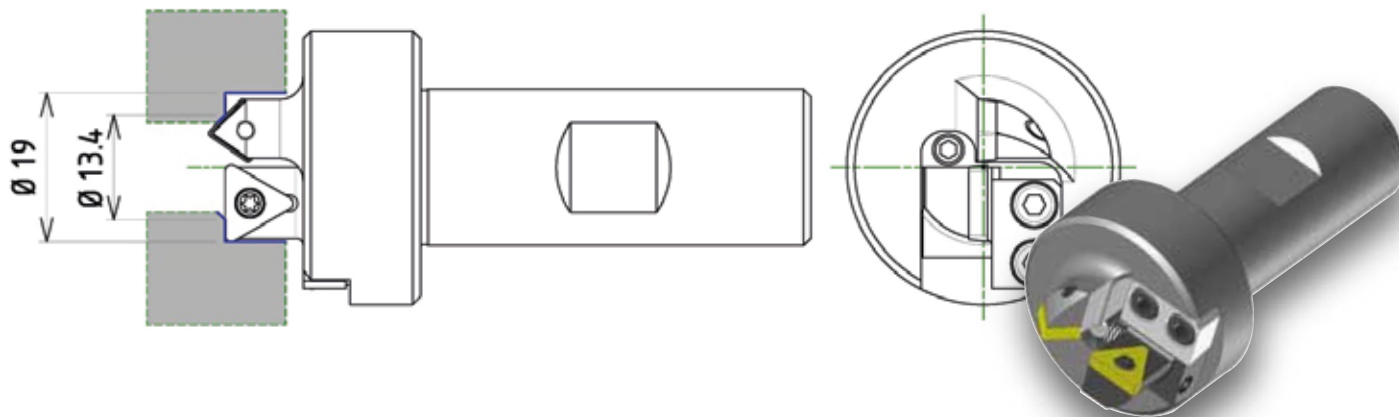

■ Porte-outil pour Raccord Gaz 1/2"

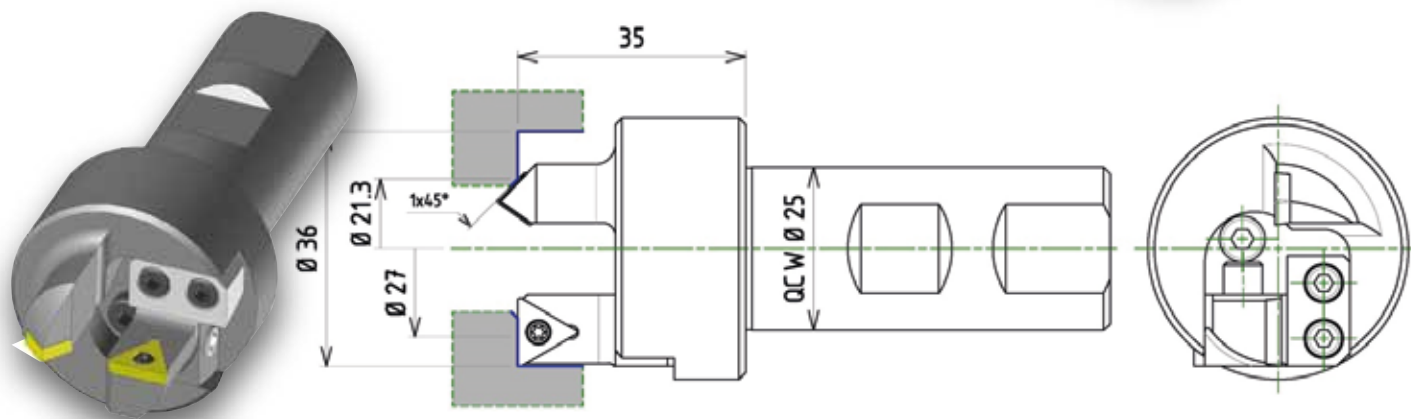

■ Porte-outil pour Raccord Gaz 1" 1/2

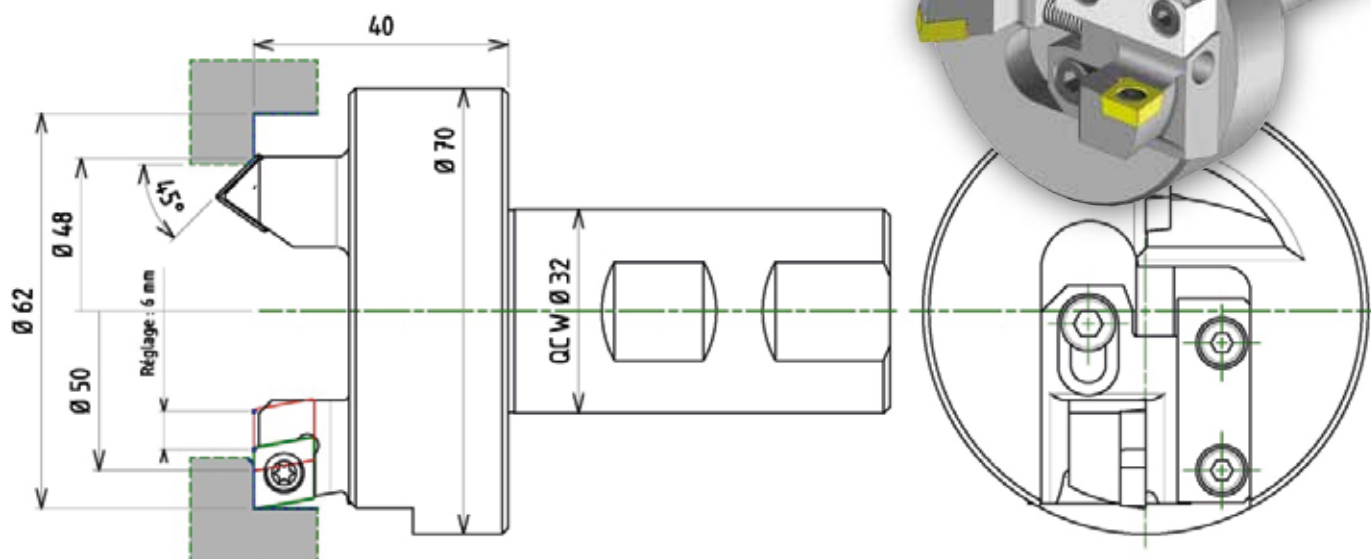

■ Porte-Outils pour raccord STAUBLI

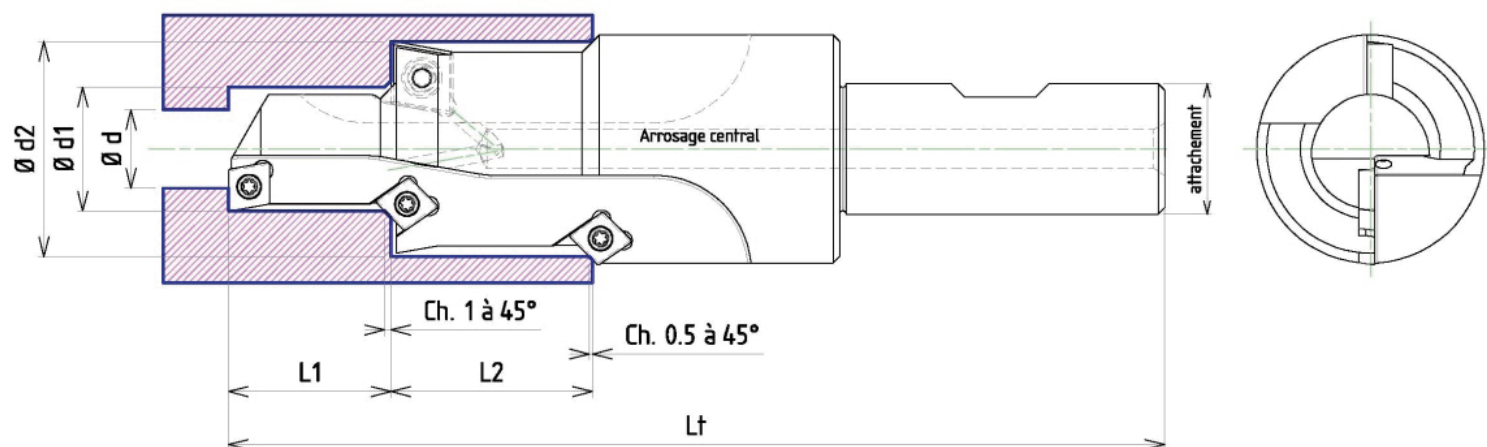

Raccord Gaz	Code G.M.O	Attache	Ød	Ød1	Ød2	L1	L2	Lt	Plaquettes
1/8 G	37400382	QC Ø 20 W	Ø6	Ø8,8	Ø22	20	23	117	1 CCMT 08-03-04 3 CPGT 04-T1-04
1/4 G	37400420	QC Ø 25 W	Ø8	Ø11,8	Ø22	20	23	124	1 CCMT 06-02-04
	37400425	QC Ø 20 W						118	3 CPGT 04-T1-04
3/8 G	37400421	QC Ø 25 W	Ø10	Ø15,25	Ø22	18	14	113	2 CPGT 04-T1-04
	37400426	QC Ø 20 W						107	2 CPGT 05-02-04
1/2 G	374003422	QC Ø 32 W	Ø12	Ø19	Ø33	25	31	150	1 CCMT 09-T3-04
	37400427	QC Ø 20 W						144	3 CCMT 06-02-04

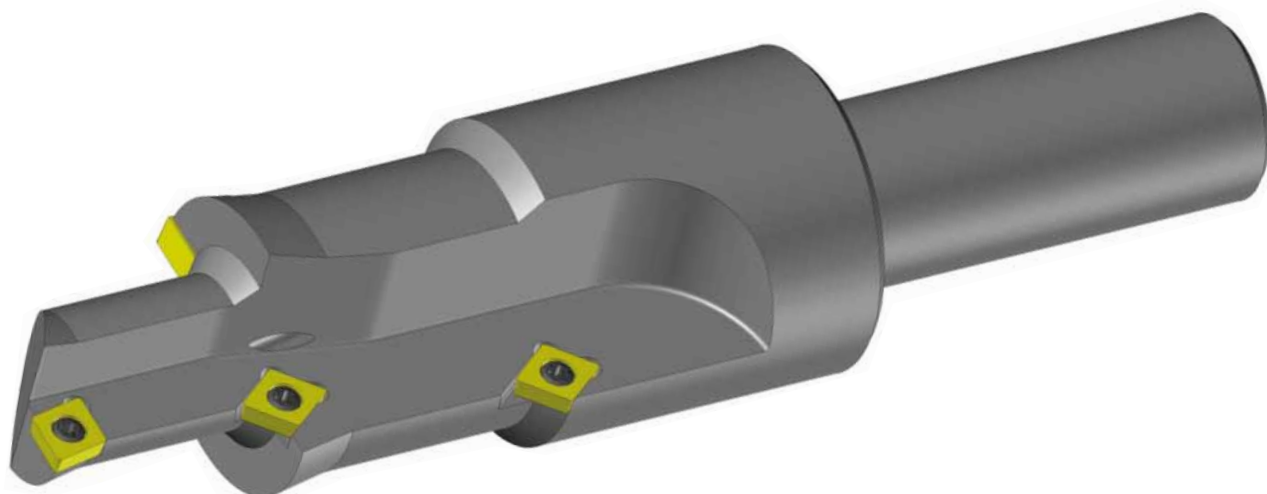

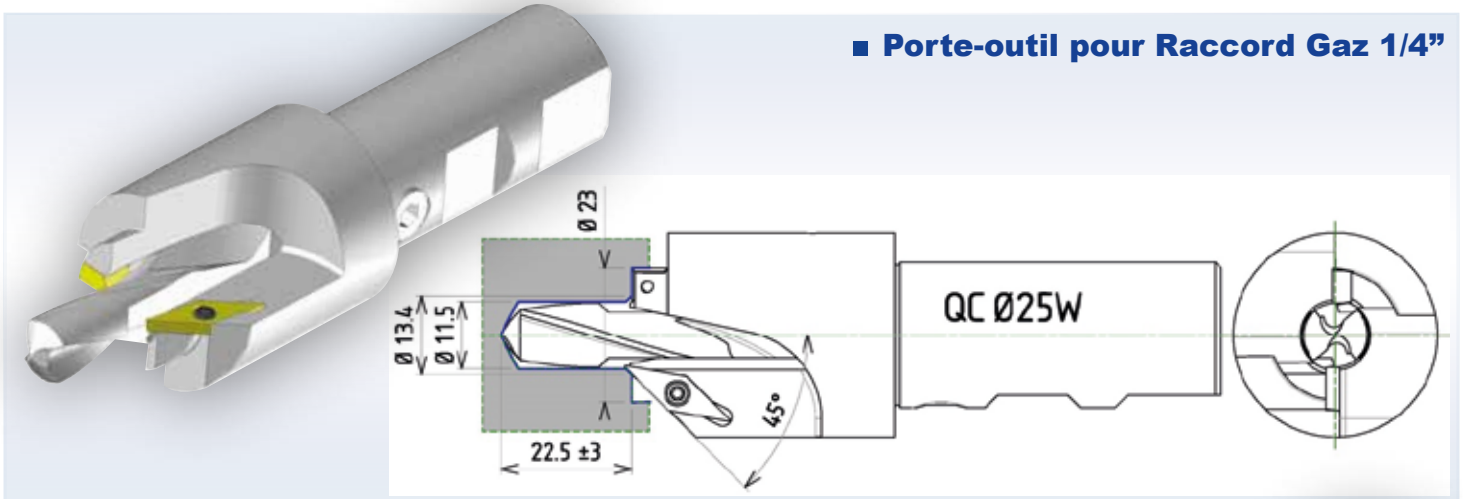

■ Porte-outil pour Raccord Gaz 1/2"

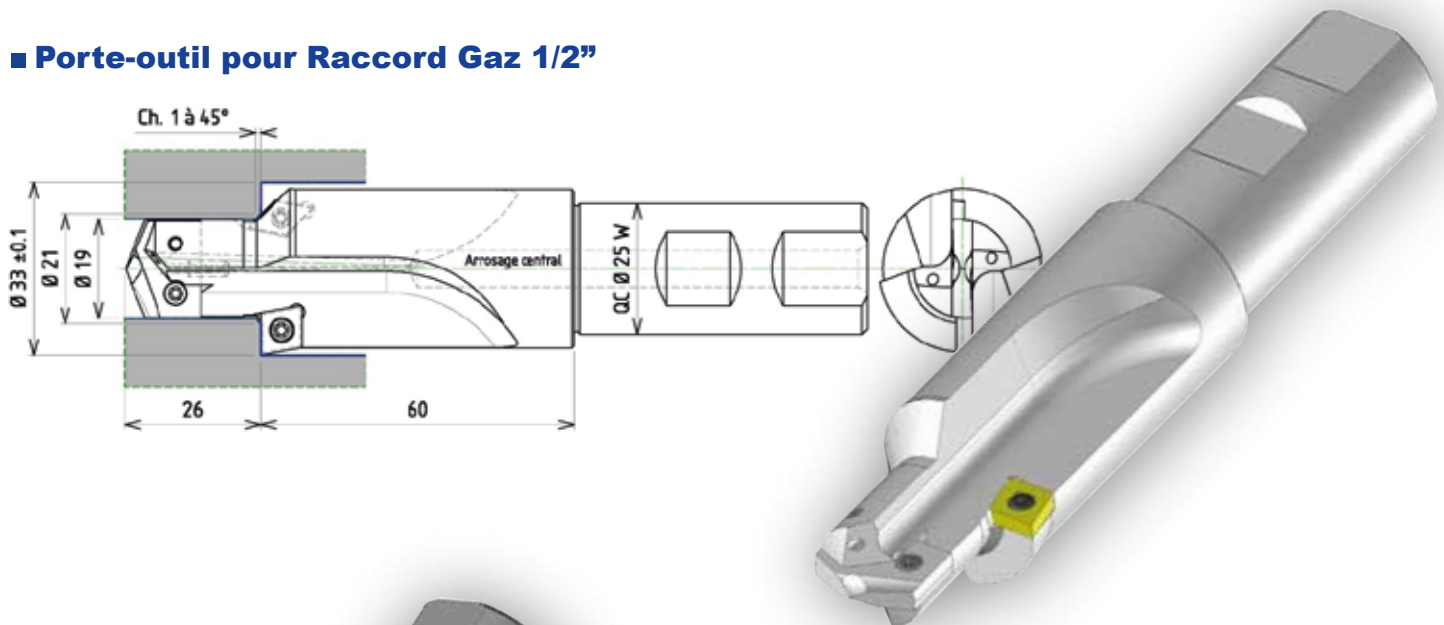

■ Porte-outil pour ebauche Clapet C2

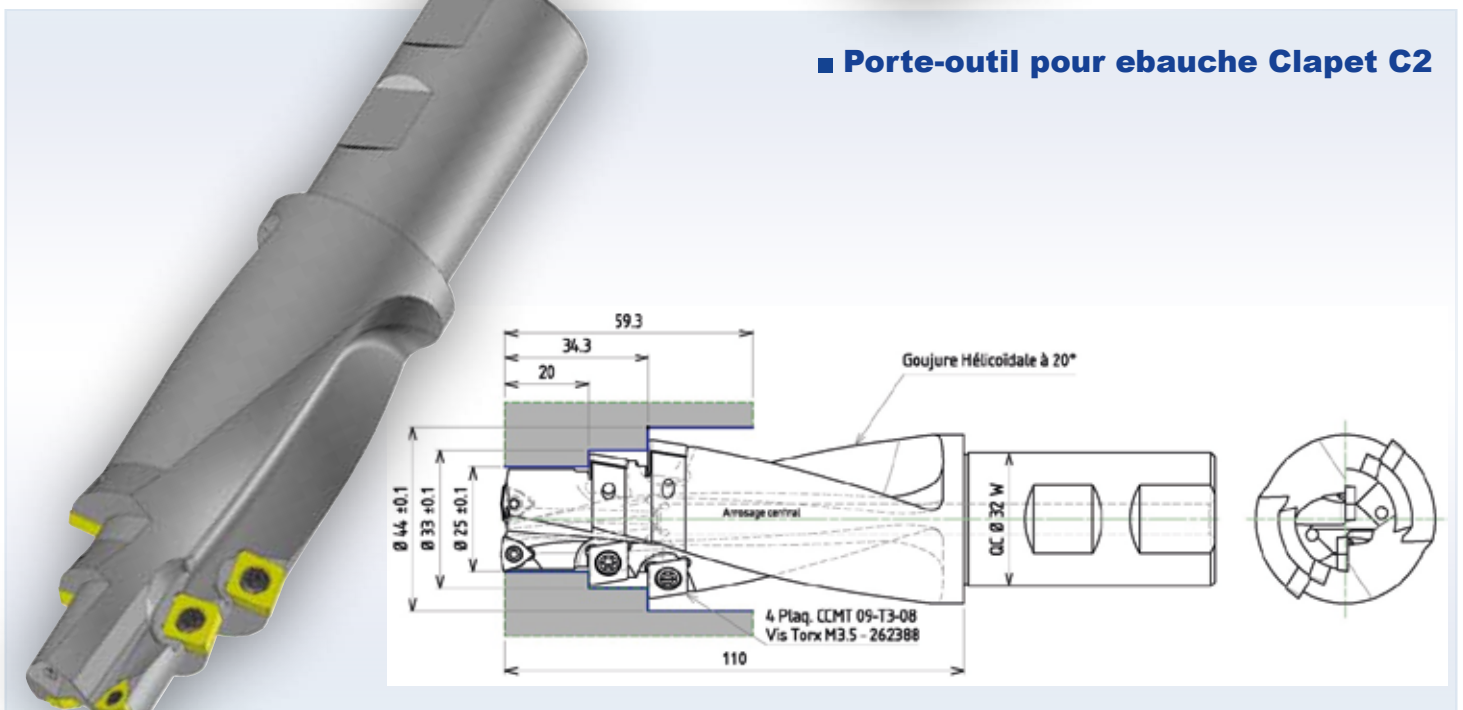

■ Porte-Outil à lamer d'ébauche combiné pour clapet

2 Etages

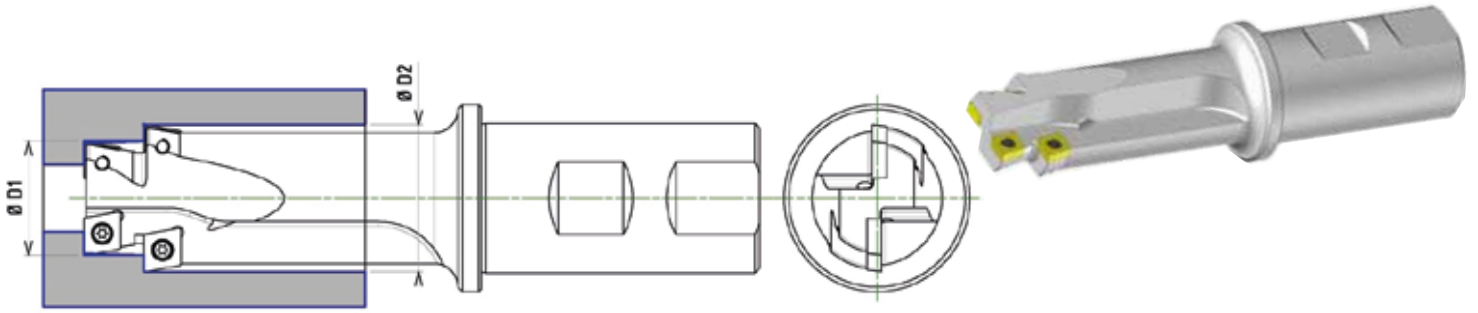

Clapet logique	Code G.M.O	Ø D1	Ø D2	Plaquette	Attachement
Calibre 4	37400596	54.6	74	CCMT 12-04-08 + assises	CAT 40
Calibre 16	33500029	24.5	31.5	CCMT 08-03-04	QC Ø 32
Calibre 25	33500061	33	44	CCMT 08-03-04	QC Ø 32
Calibre 25	33500030	33.5	44.5	CCMT 08-03-04	QC Ø 32
Calibre 32	33500031	44.5	59.5	CCMT 09-03-04	QC Ø 40
Calibre 29	37400554	31.5	33	CCMT 09-03-04	QC Ø 25

3 Etages

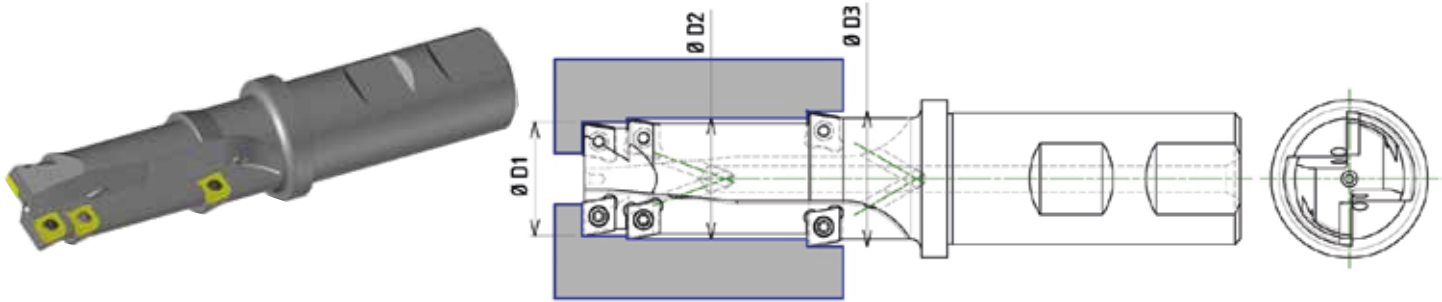

Clapet logique	Code G.M.O	Ø D1	Ø D2	Ø D3	Plaquette	Attachement
Calibre 11	37400716	21.7	23	25.7	CCMT 06-02-04	QC Ø 25
Calibre 12	37400717	21.7	23	25.7	CCMT 06-02-04	QC Ø 25
Calibre 13	37400718	17	18	20.1	CCMT 06-02-04	QC Ø 20
Calibre 16	37400720	31.25	33.5	36	CCMT 06-02-04	QC Ø 32
Calibre 18	37400674	40.8	45.5	48	CCMT 09-T3-04	QC Ø 40
Calibre 24	37400569	35.5	37.5	39	CCMT 06-02-04	QC Ø 32
Calibre 416	37400816	23	40.7	51.8	CCMT 09-T3-04	QC Ø 40

4 Etages

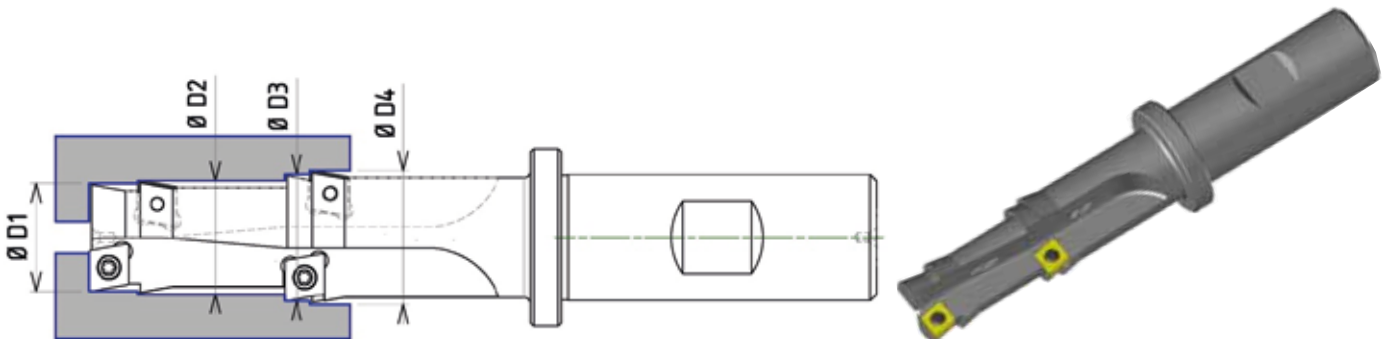

Clapet logique	Code G.M.O	Ø D1	Ø D2	Ø D3	Ø D4	Plaquette	Attachement
Calibre 10	37400715	21.7	23	25.7	26.9	CCMT 06-02-04	QC Ø 25
Calibre 14 & 15	37400719	17	18	20.1	21.3	CCMT 06-02-04	QC Ø 20
Calibre 17	37400714	31.25	33.5	36	39.2	CCMT 06-02-04	QC Ø 32
Calibre 19	37400721	40.78	45.5	48	51.9	CCMT 09-T3-04	QC Ø 40

■ Porte-outil à lamer- chanfreiner d'ébauche combiné pour clapet

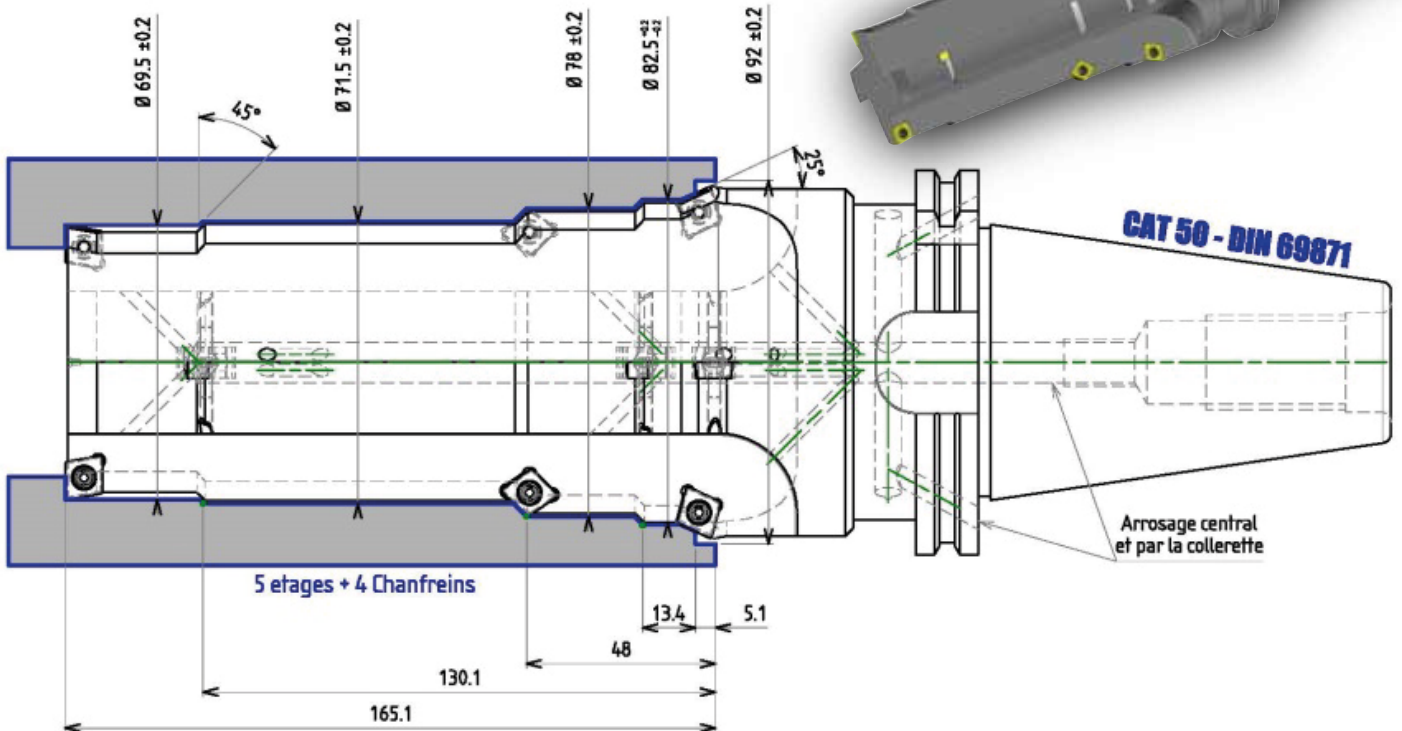
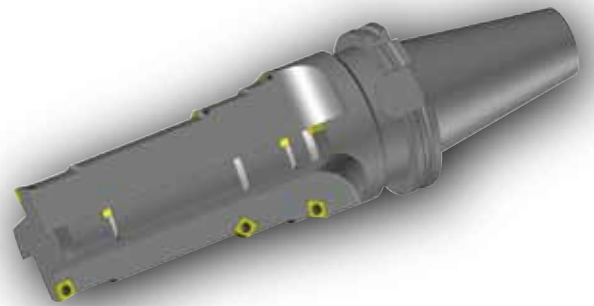
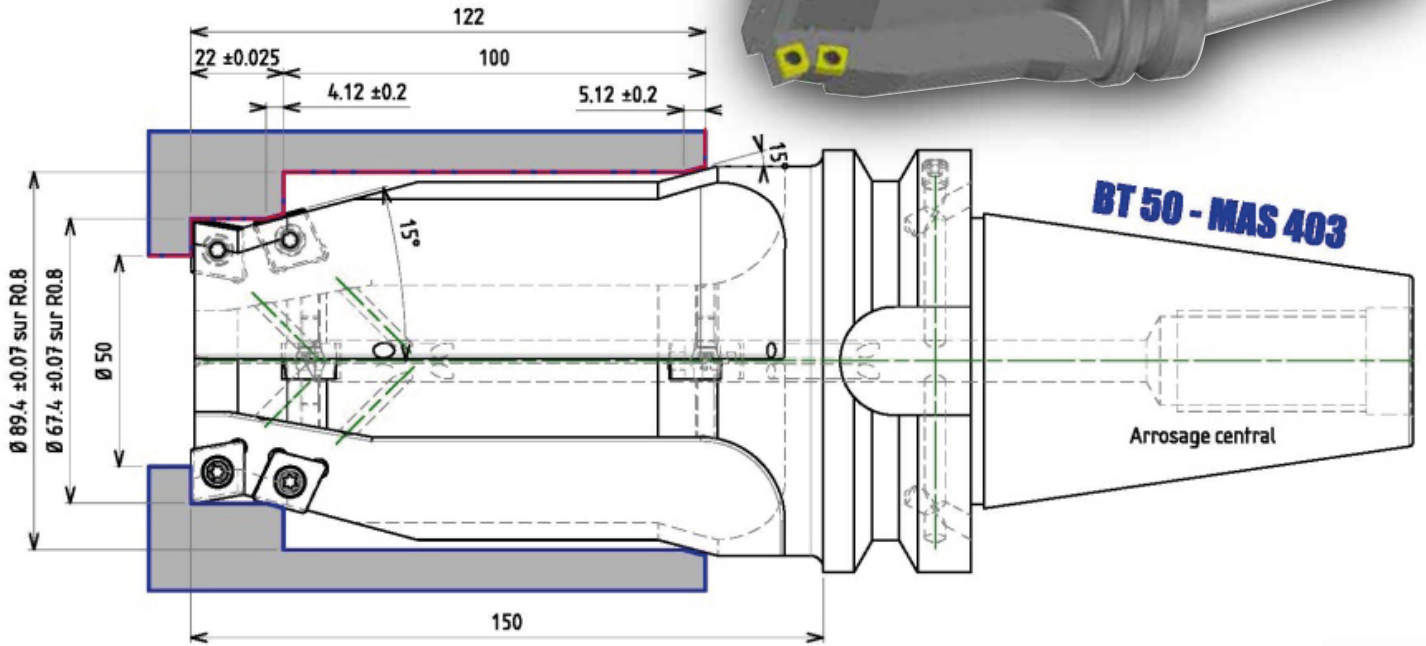
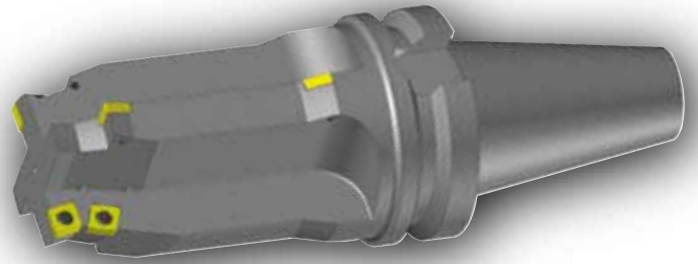

■ Barre d'Alésage

Pour Pièce type C **

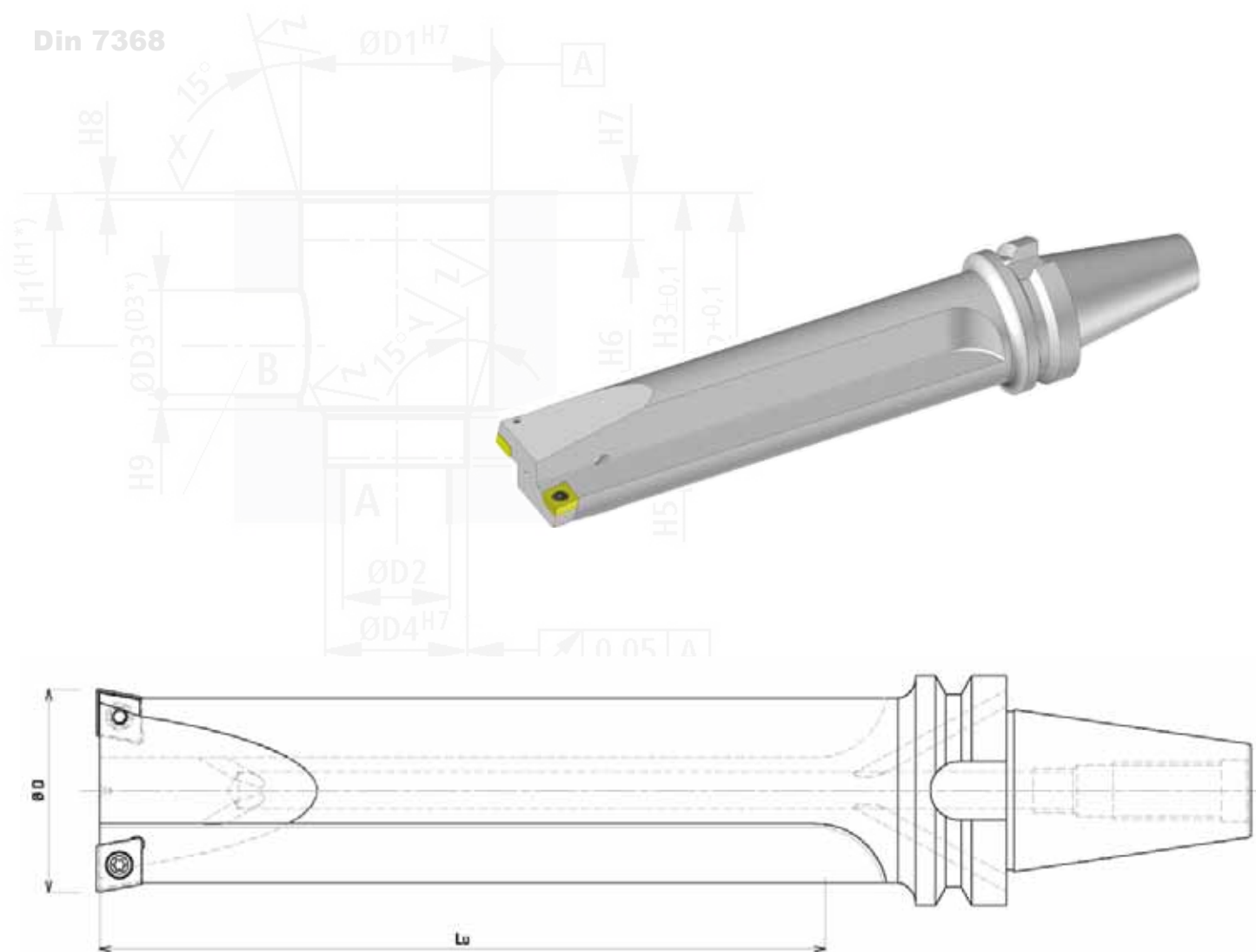

Pièce	Code G.M.O	Ø D x Lu	Plaquette	Attachement
...	33500002	31.5 x 70	2 CCMT 09-T3-04	CAT 40
...	33500003	39.5 x 70	2 CCMT 09-T3-04	CAT 40
...	33500004	59.5 x 70	2 CCMT 12-04-08	CAT 40
...	37400508	55.6 x 200	2 CCMT 12.04.08	BT 40
C26	33500019	35.6 x 120	2 CCMT 09-T3-04	CAT 40
	33500020	37.6 x 105	2 CCMT 09-T3-04	CAT 40
C27	33500021	41.6 x 135	2 CCMT 09-T3-04	CAT 40
	33500022	43.6 x 110	2 CCMT 09-T3-04	CAT 40
C31	33500023	54,5 x 100	2 CCMT 12-04-08	CAT 40
C47	33500032	27.5 x 100	2 CCMT 06-02-04	QC Ø 32

■ Barre de Finition à réglage micrométrique

Exemple de barre de finition Pour clapet logique.

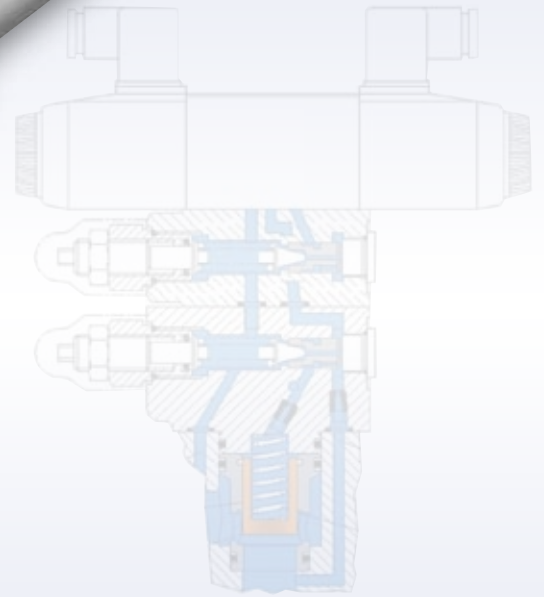
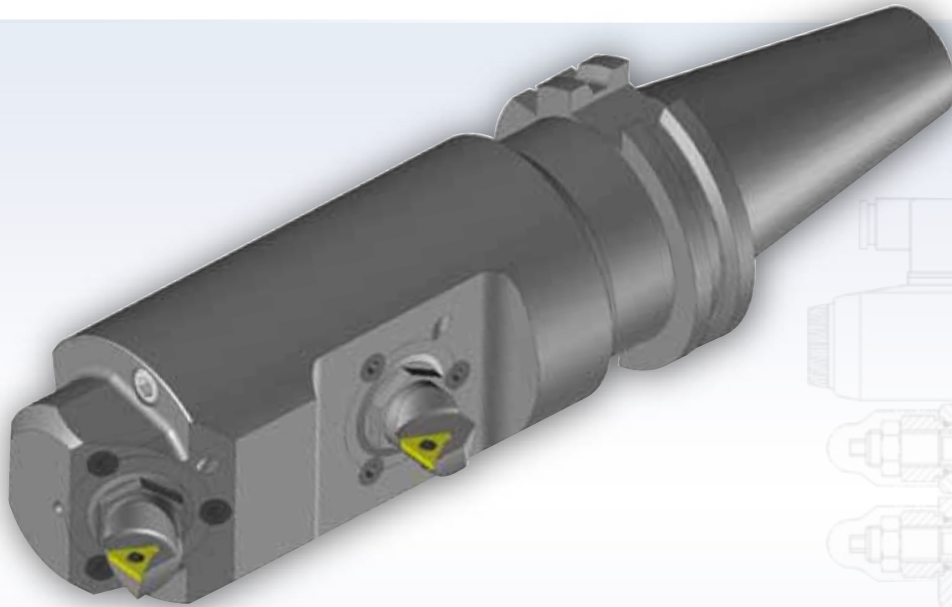

Barre de finition pour Clapet C4

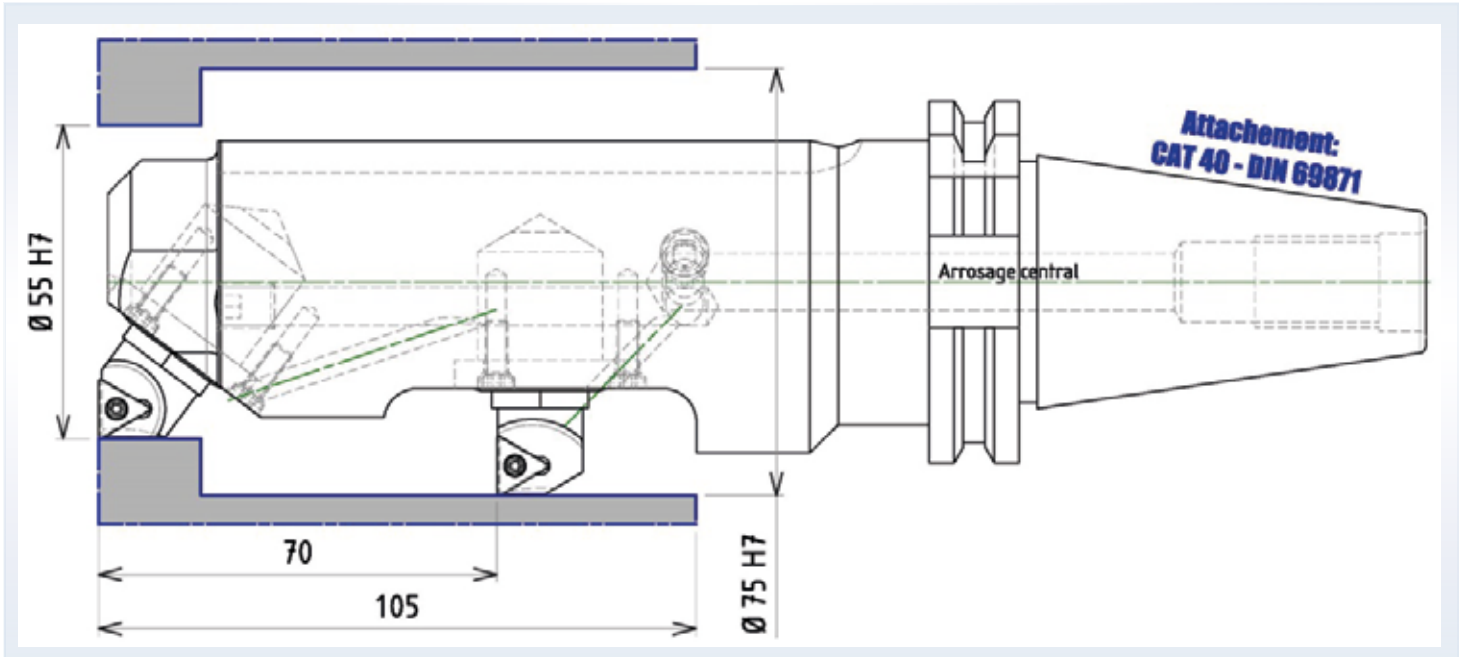

Nous réalisons tout type de porte-outils combinés d'ébauche ou de finition sur demande.

evatec tools®

Solutions sur mesure pour votre usinage
Machining solutions especially for you

CARBURE



PCBN / PCD



AÉRONAUTIQUE



TOURNAGE



USINAGE DE TROUS

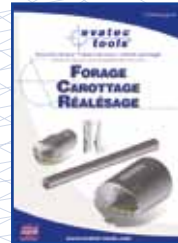

ATTACHEMENTS

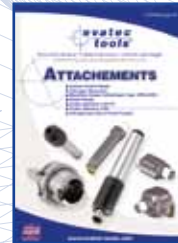

FRAISAGE

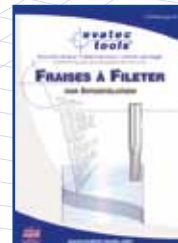
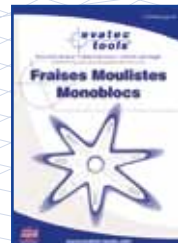

MÉTIERS / SPÉCIFIQUES



Téléchargez nos catalogues sur www.evatec-tools.com

Download our CATALOGS on www.evatec-tools.com

evatools® evamet® carbex® gmo®
coriatec® create outillage®

12, rue des Terres Rouges - Z.I. Metzange - 57100 Thionville

Tél. : 03 82 88 61 61 - E-mail : evatec@evatec-tools.fr

www.evatec-tools.com

